

# Modicon TM3

## Digital I/O Modules

### Hardware Guide

04/2014



---

The information provided in this documentation contains general descriptions and/or technical characteristics of the performance of the products contained herein. This documentation is not intended as a substitute for and is not to be used for determining suitability or reliability of these products for specific user applications. It is the duty of any such user or integrator to perform the appropriate and complete risk analysis, evaluation and testing of the products with respect to the relevant specific application or use thereof. Neither Schneider Electric nor any of its affiliates or subsidiaries shall be responsible or liable for misuse of the information contained herein. If you have any suggestions for improvements or amendments or have found errors in this publication, please notify us.

No part of this document may be reproduced in any form or by any means, electronic or mechanical, including photocopying, without express written permission of Schneider Electric.

All pertinent state, regional, and local safety regulations must be observed when installing and using this product. For reasons of safety and to help ensure compliance with documented system data, only the manufacturer should perform repairs to components.

When devices are used for applications with technical safety requirements, the relevant instructions must be followed.

Failure to use Schneider Electric software or approved software with our hardware products may result in injury, harm, or improper operating results.

Failure to observe this information can result in injury or equipment damage.

© 2014 Schneider Electric. All rights reserved.

---

# Table of Contents

---



	<b>Safety Information</b> .....	<b>7</b>
	<b>About the Book</b> .....	<b>9</b>
<b>Part I</b>	<b>TM3 General Overview</b> .....	<b>13</b>
<b>Chapter 1</b>	<b>TM3 Description</b> .....	<b>15</b>
	General Description .....	<b>16</b>
	Physical Description .....	<b>20</b>
	Accessories .....	<b>22</b>
<b>Chapter 2</b>	<b>TM3 Installation</b> .....	<b>27</b>
2.1	TM3 General Rules for Implementing .....	<b>28</b>
	Environmental Characteristics .....	<b>29</b>
	Certifications and Standards .....	<b>32</b>
2.2	TM3 Expansion Module Installation .....	<b>33</b>
	Installation and Maintenance Requirements .....	<b>34</b>
	Installation Guidelines .....	<b>37</b>
	Top Hat Section Rail (DIN rail) .....	<b>38</b>
	Assembling a Module to a Controller or Receiver Module .....	<b>41</b>
	Disassembling a Module from a Controller or Receiver Module .....	<b>43</b>
	Direct Mounting on a Panel Surface .....	<b>44</b>
2.3	TM3 Electrical Requirements .....	<b>46</b>
	Wiring Best Practices .....	<b>47</b>
	DC Power Supply Characteristics .....	<b>53</b>
<b>Part II</b>	<b>TM3 Digital Input Modules</b> .....	<b>55</b>
<b>Chapter 3</b>	<b>TM3DI8A Module 8 Inputs 120 Vac</b> .....	<b>57</b>
	TM3DI8A Presentation .....	<b>58</b>
	TM3DI8A Characteristics .....	<b>59</b>
	TM3DI8A Wiring Diagram .....	<b>61</b>
<b>Chapter 4</b>	<b>TM3DI8 / TM3DI8G Module 8 Regular Inputs 24 Vdc</b> ..	<b>63</b>
	TM3DI8 / TM3DI8G Presentation .....	<b>64</b>
	TM3DI8 / TM3DI8G Characteristics .....	<b>66</b>
	TM3DI8 / TM3DI8G Wiring Diagram .....	<b>68</b>

<b>Chapter 5</b>	<b>TM3DI16 / TM3DI16G Module 16 Regular Inputs 24 Vdc</b>	<b>69</b>
	TM3DI16 / TM3DI16G Presentation	70
	TM3DI16 / TM3DI16G Characteristics	72
	TM3DI16 / TM3DI16G Wiring Diagrams	75
<b>Chapter 6</b>	<b>TM3DI16K Module 16 Regular Inputs 24 Vdc</b>	<b>77</b>
	TM3DI16K Presentation	78
	TM3DI16K Characteristics	80
	TM3DI16K Wiring Diagrams	83
<b>Chapter 7</b>	<b>TM3DI32K Module 32 Regular Inputs 24 Vdc</b>	<b>85</b>
	TM3DI32K Presentation	86
	TM3DI32K Characteristics	88
	TM3DI32K Wiring Diagram	91
<b>Part III</b>	<b>TM3 Digital Output Modules</b>	<b>93</b>
<b>Chapter 8</b>	<b>TM3DQ8R / TM3DQ8RG Module 8 Relay Outputs 2A 24 Vdc/240 Vac</b>	<b>95</b>
	TM3DQ8R / TM3DQ8RG Presentation	96
	TM3DQ8R / TM3DQ8RG Characteristics	98
	TM3DQ8R / TM3DQ8RG Wiring Diagram	102
<b>Chapter 9</b>	<b>TM3DQ8T / TM3DQ8TG Module 8 Regular Transistor Source Outputs 0.5A 24 Vdc</b>	<b>103</b>
	TM3DQ8T / TM3DQ8TG Presentation	104
	TM3DQ8T / TM3DQ8TG Characteristics	105
	TM3DQ8T / TM3DQ8TG Wiring Diagram	107
<b>Chapter 10</b>	<b>TM3DQ8U / TM3DQ8UG Module 8 Regular Transistor Sink Outputs 0.5A 24 Vdc</b>	<b>109</b>
	TM3DQ8U / TM3DQ8UG Presentation	110
	TM3DQ8U / TM3DQ8UG Characteristics	111
	TM3DQ8U / TM3DQ8UG Wiring Diagram	113
<b>Chapter 11</b>	<b>TM3DQ16R / TM3DQ16RG Module 16 Relay Outputs 2A 24 Vdc/240 Vac</b>	<b>115</b>
	TM3DQ16R / TM3DQ16RG Presentation	116
	TM3DQ16R / TM3DQ16RG Characteristics	118
	TM3DQ16R / TM3DQ16RG Wiring Diagram	121

<b>Chapter 12</b>	<b>TM3DQ16T / TM3DQ16TG Module 16 Regular Transistor Source Outputs 0.5A 24 Vdc</b> . . . . .	<b>123</b>
	TM3DQ16T / TM3DQ16TG Presentation . . . . .	<b>124</b>
	TM3DQ16T / TM3DQ16TG Characteristics . . . . .	<b>126</b>
	TM3DQ16T / TM3DQ16TG Wiring Diagram . . . . .	<b>128</b>
<b>Chapter 13</b>	<b>TM3DQ16TK Module 16 Regular Transistor Source Outputs 0.1A 24 Vdc</b> . . . . .	<b>129</b>
	TM3DQ16TK Presentation . . . . .	<b>130</b>
	TM3DQ16TK Characteristics . . . . .	<b>132</b>
	TM3DQ16TK Wiring Diagram . . . . .	<b>134</b>
<b>Chapter 14</b>	<b>TM3DQ16U / TM3DQ16UG Module 16 Regular Transistor Sink Outputs 0.3A 24 Vdc</b> . . . . .	<b>139</b>
	TM3DQ16U / TM3DQ16UG Presentation . . . . .	<b>140</b>
	TM3DQ16U / TM3DQ16UG Characteristics . . . . .	<b>142</b>
	TM3DQ16U / TM3DQ16UG Wiring Diagram . . . . .	<b>144</b>
<b>Chapter 15</b>	<b>TM3DQ16UK Module 16 Regular Transistor Sink Outputs 0.1A 24 Vdc</b> . . . . .	<b>145</b>
	TM3DQ16UK Presentation . . . . .	<b>146</b>
	TM3DQ16UK Characteristics . . . . .	<b>148</b>
	TM3DQ16UK Wiring Diagram . . . . .	<b>150</b>
<b>Chapter 16</b>	<b>TM3DQ32TK Module 32 Regular Transistor Outputs 0.1A 24 Vdc</b> . . . . .	<b>151</b>
	TM3DQ32TK Presentation . . . . .	<b>152</b>
	TM3DQ32TK Characteristics . . . . .	<b>154</b>
	TM3DQ32TK Wiring Diagram . . . . .	<b>156</b>
<b>Chapter 17</b>	<b>TM3DQ32UK Module 32 Regular Transistor Outputs 0.1A 24 Vdc</b> . . . . .	<b>161</b>
	TM3DQ32UK Presentation . . . . .	<b>162</b>
	TM3DQ32UK Characteristics . . . . .	<b>164</b>
	TM3DQ32UK Wiring Diagram . . . . .	<b>166</b>
<b>Part IV</b>	<b>TM3 Digital Mixed Input/Output Modules</b> . . . . .	<b>169</b>
<b>Chapter 18</b>	<b>TM3DM8R / TM3DM8RG Mixed I/O Module 4 Inputs/4 Outputs</b> . . . . .	<b>171</b>
	TM3DM8R / TM3DM8RG Presentation . . . . .	<b>172</b>
	TM3DM8R / TM3DM8RG Characteristics . . . . .	<b>174</b>
	TM3DM8R / TM3DM8RG Wiring Diagram . . . . .	<b>180</b>

---

<b>Chapter 19</b>	<b>TM3DM24R / TM3DM24RG Mixed I/O Module 16</b>	
	<b>Inputs/8 Outputs</b> .....	<b>181</b>
	TM3DM24R / TM3DM24RG Presentation .....	<b>182</b>
	TM3DM24R / TM3DM24RG Characteristics .....	<b>184</b>
	TM3DM24R / TM3DM24RG Wiring Diagram .....	<b>189</b>
<b>Glossary</b>	.....	<b>191</b>
<b>Index</b>	.....	<b>193</b>

---

# Safety Information

---



## Important Information

### NOTICE

Read these instructions carefully, and look at the equipment to become familiar with the device before trying to install, operate, or maintain it. The following special messages may appear throughout this documentation or on the equipment to warn of potential hazards or to call attention to information that clarifies or simplifies a procedure.



The addition of this symbol to a Danger safety label indicates that an electrical hazard exists, which will result in personal injury if the instructions are not followed.



This is the safety alert symbol. It is used to alert you to potential personal injury hazards. Obey all safety messages that follow this symbol to avoid possible injury or death.

## **DANGER**

**DANGER** indicates an imminently hazardous situation which, if not avoided, **will result in** death or serious injury.

## **WARNING**

**WARNING** indicates a potentially hazardous situation which, if not avoided, **can result in** death or serious injury.

## **CAUTION**

**CAUTION** indicates a potentially hazardous situation which, if not avoided, **can result in** minor or moderate injury.

## **NOTICE**

**NOTICE** is used to address practices not related to physical injury.

---

## PLEASE NOTE

Electrical equipment should be installed, operated, serviced, and maintained only by qualified personnel. No responsibility is assumed by Schneider Electric for any consequences arising out of the use of this material.

A qualified person is one who has skills and knowledge related to the construction and operation of electrical equipment and its installation, and has received safety training to recognize and avoid the hazards involved.



---

# About the Book

---



## At a Glance

### Document Scope

This guide describes the hardware implementation of TM3 digital I/O expansion modules. It provides the parts description, characteristics, wiring diagrams, and installation details for TM3 digital I/O expansion modules.

### Validity Note

This document has been updated with the release of SoMachine V4.1.

This document has been updated with the release of SoMachine Basic V1.1.

The technical characteristics of the devices described in this document also appear online. To access this information online:

Step	Action
1	Go to the Schneider Electric home page <a href="http://www.schneider-electric.com">www.schneider-electric.com</a> .
2	In the <b>Search</b> box type the reference of a product or the name of a product range. <ul style="list-style-type: none"><li>• Do not include blank spaces in the model number/product range.</li><li>• To get information on grouping similar modules, use asterisks (*).</li></ul>
3	If you entered a reference, go to the <b>Product datasheets</b> search results and click on the reference that interests you. If you entered the name of a product range, go to the <b>Product Ranges</b> search results and click on the product range that interests you.
4	If more than one reference appears in the <b>Products</b> search results, click on the reference that interests you.
5	Depending on the size of your screen, you may need to scroll down to see the data sheet.
6	To save or print a data sheet as a .pdf file, click <b>Download XXX product datasheet</b> .

The characteristics that are presented in this manual should be the same as those characteristics that appear online. In line with our policy of constant improvement, we may revise content over time to improve clarity and accuracy. If you see a difference between the manual and online information, use the online information as your reference.

## Related Documents

Title of Documentation	Reference Number
Modicon TM3 Expansion Modules Configuration - Programming Guide (SoMachine Basic)	EIO0000001396 (ENG) EIO0000001397 (FRA) EIO0000001398 (GER) EIO0000001399 (SPA) EIO0000001400 (ITA) EIO0000001401 (CHS) EIO0000001374 (POR) EIO0000001375 (TUR)
Modicon TM3 Expansion Modules Configuration - Programming Guide (SoMachine)	EIO0000001402 (ENG) EIO0000001403 (FRA) EIO0000001404 (GER) EIO0000001405 (SPA) EIO0000001406 (ITA) EIO0000001407 (CHS)
Modicon M221 Logic Controller - Hardware Guide	EIO0000001384 (ENG) EIO0000001385 (FRA) EIO0000001386 (GER) EIO0000001387 (SPA) EIO0000001388 (ITA) EIO0000001389 (CHS) EIO0000001370 (POR) EIO0000001371(TUR)
Modicon M241 Logic Controller - Hardware Guide	EIO0000001384 (ENG) EIO0000001385 (FRA) EIO0000001386 (GER) EIO0000001387 (SPA) EIO0000001388 (ITA) EIO0000001389 (CHS)
Modicon M251 Logic Controller - Hardware Guide	EIO0000001384 (ENG) EIO0000001385 (FRA) EIO0000001386 (GER) EIO0000001387 (SPA) EIO0000001388 (ITA) EIO0000001389 (CHS)
TM3 Digital I/O Modules Instruction Sheet	HRB59605

You can download these technical publications and other technical information from our website at [www.schneider-electric.com](http://www.schneider-electric.com).

## Product Related Information

### **DANGER**

#### **HAZARD OF ELECTRIC SHOCK, EXPLOSION OR ARC FLASH**

- Disconnect all power from all equipment including connected devices prior to removing any covers or doors, or installing or removing any accessories, hardware, cables, or wires except under the specific conditions specified in the appropriate hardware guide for this equipment.
- Always use a properly rated voltage sensing device to confirm the power is off where and when indicated.
- Replace and secure all covers, accessories, hardware, cables, and wires and confirm that a proper ground connection exists before applying power to the unit.
- Use only the specified voltage when operating this equipment and any associated products.

**Failure to follow these instructions will result in death or serious injury.**

This equipment has been designed to operate outside of any hazardous location. Only install this equipment in zones known to be free of a hazardous atmosphere.

### **DANGER**

#### **POTENTIAL FOR EXPLOSION**

Install and use this equipment in non-hazardous locations only.

**Failure to follow these instructions will result in death or serious injury.**

### **WARNING**

#### **LOSS OF CONTROL**

- The designer of any control scheme must consider the potential failure modes of control paths and, for certain critical control functions, provide a means to achieve a safe state during and after a path failure. Examples of critical control functions are emergency stop and overtravel stop, power outage and restart.
- Separate or redundant control paths must be provided for critical control functions.
- System control paths may include communication links. Consideration must be given to the implications of unanticipated transmission delays or failures of the link.
- Observe all accident prevention regulations and local safety guidelines.<sup>1</sup>
- Each implementation of this equipment must be individually and thoroughly tested for proper operation before being placed into service.

**Failure to follow these instructions can result in death, serious injury, or equipment damage.**

---

<sup>1</sup> For additional information, refer to NEMA ICS 1.1 (latest edition), "Safety Guidelines for the Application, Installation, and Maintenance of Solid State Control" and to NEMA ICS 7.1 (latest edition), "Safety Standards for Construction and Guide for Selection, Installation and Operation of Adjustable-Speed Drive Systems" or their equivalent governing your particular location.

 **WARNING**

**UNINTENDED EQUIPMENT OPERATION**

- Only use software approved by Schneider Electric for use with this equipment.
- Update your application program every time you change the physical hardware configuration.

**Failure to follow these instructions can result in death, serious injury, or equipment damage.**

---

# Part I

## TM3 General Overview

---

### What Is in This Part?

This part contains the following chapters:

Chapter	Chapter Name	Page
1	TM3 Description	15
2	TM3 Installation	27



---

# Chapter 1

## TM3 Description

---

### What Is in This Chapter?

This chapter contains the following topics:

Topic	Page
General Description	16
Physical Description	20
Accessories	22

## General Description

### Introduction

The range of TM3 digital I/O expansion modules includes:

- Input modules
- Output modules
- Mixed input/output modules

All TM3 digital I/O expansion modules are equipped with (depending on the reference):

- Removable screw terminal blocks
- Removable spring terminal blocks
- HE10 (MIL 20) connectors

For modules with HE10 (MIL 20) connectors, a group of products known as Telefast 2 are available that enable these modules to be quickly connected to sensors and actuators.

### TM3 Digital Input Modules

The following table shows the TM3 digital input expansion modules, with corresponding channel type, nominal voltage/current, and terminal type:

Reference	Channels	Channel Type	Voltage Current	Terminal Type / Pitch
TM3DI8A ( <a href="#">see page 57</a> )	8	Regular inputs	120 Vac 7.5 mA	Removable screw terminal block / 5.08 mm
TM3DI8 ( <a href="#">see page 63</a> )	8	Regular inputs	24 Vdc 7 mA	Removable screw terminal block / 5.08 mm
TM3DI8G ( <a href="#">see page 63</a> )	8	Regular inputs	24 Vdc 7 mA	Removable spring terminal block / 5.08 mm
TM3DI16 ( <a href="#">see page 69</a> )	16	Regular inputs	24 Vdc 7 mA	Removable screw terminal blocks / 3.81 mm
TM3DI16G ( <a href="#">see page 69</a> )	16	Regular inputs	24 Vdc 7 mA	Removable spring terminal blocks / 3.81 mm
TM3DI16K ( <a href="#">see page 77</a> )	16	Regular inputs	24 Vdc 5 mA	HE10 (MIL 20) connector
TM3DI32K ( <a href="#">see page 85</a> )	32	Regular inputs	24 Vdc 5 mA	HE10 (MIL 20) connector



### TM3 Digital Output Modules

The following table shows the TM3 digital output expansion modules, with corresponding channel type, nominal voltage/current, and terminal type:

Reference	Channels	Channel Type	Voltage Current	Terminal Type / Pitch
TM3DQ8R ( <i>see page 95</i> )	8	Relay outputs	24 Vdc / 240 Vac 7 A maximum per common line / 2 A maximum per output	Removable screw terminal block / 5.08 mm
TM3DQ8RG ( <i>see page 95</i> )	8	Relay outputs	24 Vdc / 240 Vac 7 A maximum per common line / 2 A maximum per output	Removable spring terminal block / 5.08 mm
TM3DQ8T ( <i>see page 103</i> )	8	Regular transistor outputs (source)	24 Vdc 4 A maximum per common line/0.5 A maximum per output	Removable screw terminal block / 5.08 mm
TM3DQ8TG ( <i>see page 103</i> )	8	Regular transistor outputs (source)	24 Vdc 4 A maximum per common line/0.5 A maximum per output	Removable spring terminal block / 5.08 mm
TM3DQ8U ( <i>see page 109</i> )	8	Regular transistor outputs (sink)	24 Vdc 4 A maximum per common line/0.5 A maximum per output	Removable screw terminal block / 5.08 mm
TM3DQ8UG ( <i>see page 109</i> )	8	Regular transistor outputs (sink)	24 Vdc 4 A maximum per common line/0.5 A maximum per output	Removable spring terminal block / 5.08 mm
TM3DQ16R ( <i>see page 115</i> )	16	Relay outputs	24 Vdc / 240 Vac 8 A maximum per common line / 2 A maximum per output	Removable screw terminal blocks / 3.81 mm
TM3DQ16RG ( <i>see page 115</i> )	16	Relay outputs	24 Vdc / 240 Vac 8 A maximum per common line / 2 A maximum per output	Removable spring terminal blocks / 3.81 mm
TM3DQ16T ( <i>see page 123</i> )	16	Regular transistor outputs (source)	24 Vdc 4 A maximum per common line / 0.5 A maximum per output	Removable screw terminal blocks / 3.81 mm

Reference	Channels	Channel Type	Voltage Current	Terminal Type / Pitch
TM3DQ16TG <i>(see page 123)</i>	16	Regular transistor outputs (source)	24 Vdc 4 A maximum per common line / 0.5 A maximum per output	Removable spring terminal blocks / 3.81 mm
TM3DQ16U <i>(see page 139)</i>	16	Regular transistor outputs (sink)	24 Vdc 2 A maximum per common line / 0.4 A maximum per output	Removable screw terminal blocks / 3.81 mm
TM3DQ16UG <i>(see page 139)</i>	16	Regular transistor outputs (sink)	24 Vdc 2 A maximum per common line / 0.4 A maximum per output	Removable spring terminal blocks / 3.81 mm
TM3DQ16TK <i>(see page 123)</i>	16	Regular transistor outputs (source)	24 Vdc 2 A maximum per common line / 0.1 A maximum per output	HE10 (MIL 20) connector
TM3DQ16UK <i>(see page 145)</i>	16	Regular transistor outputs (sink)	24 Vdc 2 A maximum per common line / 0.1 A maximum per output	HE10 (MIL 20) connector
TM3DQ32TK <i>(see page 151)</i>	32	Regular transistor outputs (source)	24 Vdc 2 A maximum per common line / 0.1 A maximum per output	HE10 (MIL 20) connectors
TM3DQ32UK <i>(see page 161)</i>	32	Regular transistor outputs (sink)	24 Vdc 2 A maximum per common line / 0.1 A maximum per output	HE10 (MIL 20) connectors

### TM3 Digital Mixed Input/Output Modules

This following table shows the TM3 mixed I/O modules, with corresponding channel type, nominal voltage/current, and terminal type:

Reference	Channels	Channel Type	Voltage Current	Terminal Type / Pitch
TM3DM8R ( <i>see page 171</i> )	4	Regular inputs	24 Vdc 7 mA	Removable screw terminal block / 5.08 mm
	4	Relay outputs	24 Vdc / 240 Vac 7 A maximum per common line / 2 A maximum per output	
TM3DM8RG ( <i>see page 171</i> )	4	Regular inputs	24 Vdc 7 mA	Removable spring terminal block / 5.08 mm
	4	Relay outputs	24 Vdc / 240 Vac 7 A maximum per common line / 2 A maximum per output	
TM3DM24R ( <i>see page 181</i> )	16	Regular inputs	24 Vdc 7 mA	Removable screw terminal blocks / 3.81 mm
	8	Relay outputs	24 Vdc / 240 Vac 7 A maximum per common line / 2 A maximum per output	
TM3DM24RG ( <i>see page 181</i> )	16	Regular inputs	24 Vdc 7 mA	Removable spring terminal blocks / 3.81 mm
	8	Relay outputs	24 Vdc / 240 Vac 7 A maximum per common line / 2 A maximum per output	

## Physical Description

### Introduction

This section describes the physical characteristics of the TM3 modules. The modules, depending on the reference, support one of two different types of connectors:

- Removable screw or spring terminal block
- HE10 (MIL 20) connector

### TM3 with Removable Screw or Spring Terminal Block

The following figure shows the main elements of a TM3 expansion module with removable screw or spring terminal block:

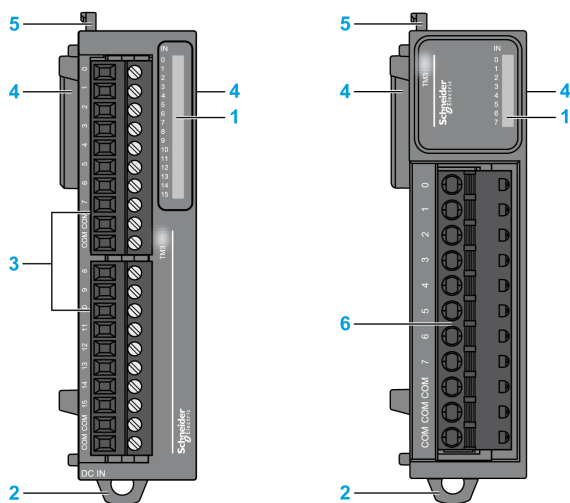

This table describes the main elements of the TM3 expansion modules shown above:

Label	Elements	
1	LEDs for displaying the state of the I/O channel.	
2	Clip-on lock for 35 mm (1.38 in.) top hat section rail (DIN-rail).	DIN Rail ( <a href="#">see page 38</a> )
3	Removable terminal block.	Rules for Removable Screw Terminal Block ( <a href="#">see page 49</a> )
4	Expansion connector for TM3 I/O bus (one on each side).	
5	Locking device for attachment to the previous module.	
6	Removable terminal block.	Rules for Removable Spring Terminal Block ( <a href="#">see page 50</a> )

### TM3 with HE10 (MIL 20) Connector

The following figure shows the main elements of a TM3 expansion module with HE10 (MIL 20) connector:

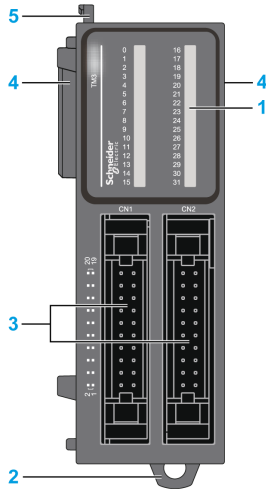

This table describes the main elements of the TM3 expansion module shown above:

Label	Elements	
1	LEDs for displaying the state of the I/O channel.	
2	Clip-on lock for 35 mm (1.38 in.) top hat section rail (DIN-rail).	DIN Rail ( <a href="#">see page 38</a> )
3	HE10 (MIL 20) connector socket.	Cable list
4	Expansion connector for TM3 I/O bus (one on each side).	
5	Locking device for attachment to the previous module.	

## Accessories

### Overview

This section describes the accessories, cables, and Telefast.

### Accessories

Reference	Description	Use	Quantity
TMAT2MSET	Set of 5 removable screw terminal block	Connects the module I/Os.	1
TMAT2MSETG	Set of 5 removable spring terminal block	Connects the module I/Os.	1
AB1AB8P35	End brackets	Help secure the logic controller or receiver module and their expansion modules on a top hat section rail (DIN rail).	1
TM2XMTGB	Grounding Bar	Connects the cable shield and the module to the functional ground.	1
TM200RSRCEMC	Shielding take-up clip	Mounts and connects the ground to the cable shielding.	25 pack
TMAM2	Mounting Kit	Mounts the controller and I/O modules directly to a flat, vertical panel.	1

### Cables

Reference	Description	Details	Length
TWDFCW30K	Digital I/O cables with free wires for 20-pin Modular controller	Cable equipped at a one end with an HE10 connector. (AWG 22 / 0.34 mm <sup>2</sup> )	3 m (9.84 ft)
TWDFCW50K		Cable equipped at a one end with an HE10 connector. (AWG 22 / 0.34 mm <sup>2</sup> )	5 m (16.4 ft)
ABFT20E050	Telefast cables for digital I/O expansion modules	Cable equipped with HE10 (MIL 20) connector at each end. (AWG 28 / 0.08 mm <sup>2</sup> )	0.5 m (1.64 ft)
ABFT20E100		Cable equipped with HE10 (MIL 20) connector at each end. (AWG 28 / 0.08 mm <sup>2</sup> )	1 m (3.28 ft)
ABFT20E200		Cable equipped with HE10 (MIL 20) connector at each end. (AWG 28 / 0.08 mm <sup>2</sup> )	2 m (6.56 ft)

**TWDFCW••K Cable Description**

The following table provides specifications for the TWDFCW30K/50K with free wires for 20-pin connectors (HE10 or MIL20):

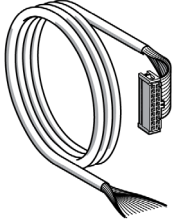
Cable illustration	Pin Connector	Wire Color
	1	White
	2	Brown
	3	Green
	4	Yellow
	5	Grey
	6	Pink
	7	Blue
	8	Red
	9	Black
	10	Violet
	11	Grey and pink
	12	Red and blue
	13	White and green
	14	Brown and green
	15	White and yellow
	16	Yellow and brown
	17	White and grey
	18	Grey and brown
	19	White and pink
	20	Pink and brown

## Telefast Pre-Wiring Sub-bases

The following illustration shows the Telefast system:

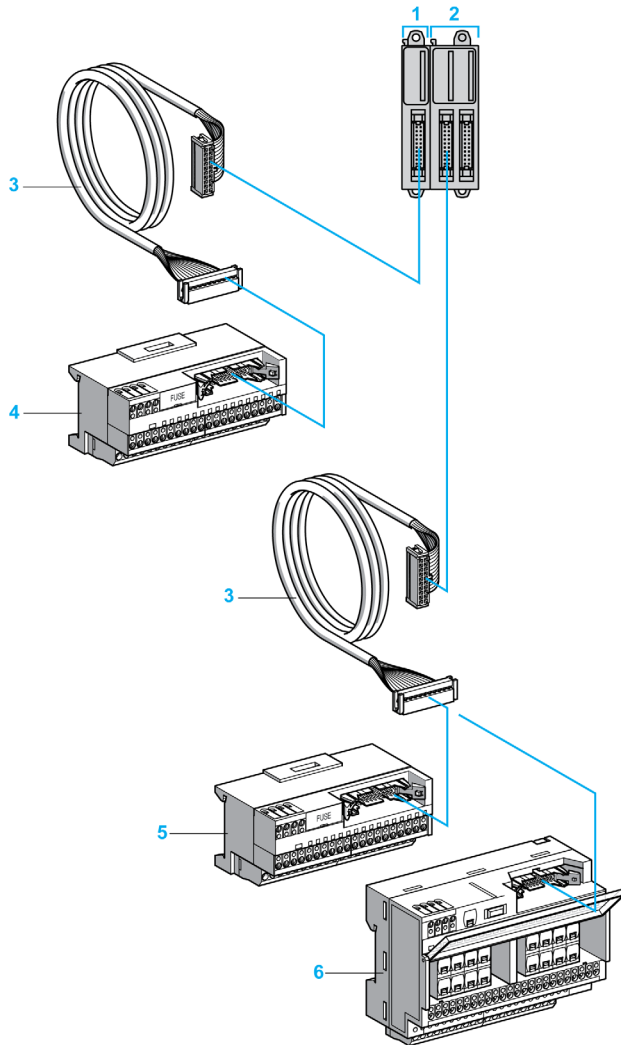

- 1 TM3DI16K / TM3DI32K
- 2 TM3DQ16TK / TM3DQ32TK
- 3 Cable (ABFT20E\*\*0) equipped with a 20-way HE 10 connector at each end. This cable is available in 0.5, 1 and 2 meter lengths (AWG 28/0.08 mm<sup>2</sup>)
- 4 16 channel sub-base (ABE7E16EPN20) for input extension modules.
- 5 16 channel sub-base (ABE7E16SPN20) for output extension modules.
- 6 16 channel sub-base (ABE7E16SPN22 or ABE7E16SRM20) for output extension modules.



**Telefast Sub-base Reference**

The following table describes compatibility between the TM3 expansion modules and Telefast components:

Telefast Module Description			TM3 Expansion Modules	
Type	Channel	Reference	8 Inputs 16 Inputs 32 Inputs	8 Outputs 16 Outputs 32 Outputs
Passive connection sub-bases	16	ABE7E16EPN20	X	–
		ABE7E16SPN20	–	X
		ABE7E16SPN22	–	X
Relay output connection sub-base	16	ABE7E16SRM20	–	X



---

# Chapter 2

## TM3 Installation

---

### What Is in This Chapter?

This chapter contains the following sections:

Section	Topic	Page
2.1	TM3 General Rules for Implementing	28
2.2	TM3 Expansion Module Installation	33
2.3	TM3 Electrical Requirements	46

## Section 2.1

### TM3 General Rules for Implementing

---

#### What Is in This Section?

This section contains the following topics:

Topic	Page
Environmental Characteristics	29
Certifications and Standards	32

## Environmental Characteristics

### Enclosure Requirements

TM3 expansion module components are designed as Zone B, Class A industrial equipment according to IEC/CISPR Publication 11. If they are used in environments other than those described in these standards, or in environments that do not meet the specifications in this manual the ability to meet electromagnetic compatibility requirements in the presence of conducted and/or radiated interference may be reduced.

All TM3 expansion module components meet European Community (CE) requirements for open equipment as defined by IEC/EN 61131-2. You must install them in an enclosure designed for the specific environmental conditions and to minimize the possibility of unintended contact with hazardous voltages. Use metal enclosures to improve the electromagnetic immunity of your TM3 expansion module components. Use enclosures with a keyed locking mechanism to minimize unauthorized access.

### Environmental Characteristics

All the TM3 expansion module components are electrically isolated between the internal electronic circuit and the input/output channels. This equipment meets CE requirements as indicated in the table below. This equipment is intended for use in a Pollution Degree 2 industrial environment.

## **WARNING**

### **UNINTENDED EQUIPMENT OPERATION**

Do not exceed any of the rated values specified in the environmental and electrical characteristics tables.

**Failure to follow these instructions can result in death, serious injury, or equipment damage.**

The following table shows the general environmental characteristics:

Characteristic		Specification
Standard compliance	IEC/EN 61131-2 IEC/EN 61010-2-201	
Ambient operating temperature	Horizontal installation	-10...55 °C (14...131 °F)
	Vertical installation	-10...35 °C (14...95 °F)
Storage temperature		-25...70 °C (- 13...158 °F)
Relative humidity	Transport and storage	10...95 % (non-condensing)
	Operation	10...95 % (non-condensing)
Degree of pollution	IEC/EN 60664-1	2
Degree of protection	IEC/EN 61131-2	IP20
Machine Safety conformance	IEC/EN 61010-2-201	Yes
Corrosion immunity		Atmosphere free from corrosive gases
Operating altitude		0...2000 m (0...6560 ft)
Storage altitude		0...3000 m (0...9843 ft)
Vibration resistance	IEC/EN 61131-2 Panel mounting or mounted on a top hat section rail (DIN rail)	3.5 mm (0.13 in) fixed amplitude from 5...8.5 Hz 29.4 m/s <sup>2</sup> or 96.45 ft/s <sup>2</sup> (3 g <sub>n</sub> ) fixed acceleration from 8.7...150 Hz
Mechanical shock resistance		147 m/s <sup>2</sup> or 482.28 ft/s <sup>2</sup> (15 g <sub>n</sub> ) for a duration of 11 ms

## Electromagnetic Susceptibility

The TM3 expansion module components meets electromagnetic susceptibility specifications as indicated in the following table:

Characteristic	Designed to specification	Range		
Electrostatic discharge	IEC/EN 61000-4-2	8 kV (air discharge) 4 kV (contact discharge)		
Radiated electromagnetic field	IEC/EN 61000-4-3	10 V/m (80...1000 MHz) 3 V/m (1.4...2 GHz) 1 V/m (2...3 GHz)		
Magnetic field	IEC/EN 61000-4-8	30 A/m 50 Hz, 60 Hz		
Fast transients burst	IEC/EN 61000-4-4	–	CM <sup>1</sup> and DM <sup>2</sup>	
		AC/DC Power lines	–	
		Relay Outputs	2 kV	
		24 Vdc I/Os	1 kV	
		Analog I/Os	–	
		Communication line	–	
Surge immunity	IEC/EN 61000-4-5 IEC/EN 61131-2	–	CM <sup>1</sup>	DM <sup>2</sup>
		DC Power lines	1 kV	0.5 kV
		AC Power lines	2 kV	1 kV
		Relay Outputs	2 kV	1 kV
		24 Vdc I/Os	1 kV	–
		Shielded cable (between shield and ground)	–	
Induced electromagnetic field	IEC/EN 61000-4-6	10 Vrms (0.15...80 MHz)		
Conducted emission	IEC/EN 55011 (IEC/CISPR Publication 11)	AC power line:		
		<ul style="list-style-type: none"> <li>● 0.15...0.5 MHz: 79 dB<math>\mu</math>V/m QP / 66 dB<math>\mu</math>V/m AV</li> <li>● 0.5...300 MHz: 73 dB<math>\mu</math>V/m QP / 60 dB<math>\mu</math>V/m AV</li> </ul>		
Radiated emission	IEC/EN 55011 (IEC/CISPR Publication 11)	AC/DC power line:		
		<ul style="list-style-type: none"> <li>● 10...150 kHz: 120...69 dB<math>\mu</math>V/m QP</li> <li>● 150...1500 kHz: 79...63 dB<math>\mu</math>V/m QP</li> <li>● 1.5...30 MHz: 63 dB<math>\mu</math>V/m QP</li> </ul>		
		Class A, 10 m distance:		
		<ul style="list-style-type: none"> <li>● 30...230 MHz: 40 dB<math>\mu</math>V/m QP</li> <li>● 230...1000 MHz: 47 dB<math>\mu</math>V/m QP</li> </ul>		
<sup>1</sup> Common Mode <sup>2</sup> Differential Mode				

## Certifications and Standards

### Introduction

The TM3 expansion modules are designed to conform to the main national and international standards concerning electronic industrial control devices:

- IEC/EN 61131-2
- UL 508

The TM3 have obtained, or in the process of obtaining, the following conformity marks:

- CE
- cULus Listing Mark
- C-Tick

The TM3 expansion modules comply with the main national and international Directives and Regulations concerning electronic industrial control devices:

- Europe RoHS:
  - Exemption annex III 7(a)
  - Exemption annex III 7(c)-I
  - Exemption annex III 34

- China RoHS regulations



- REACH v9



---

## Section 2.2

### TM3 Expansion Module Installation

---

#### What Is in This Section?

This section contains the following topics:

Topic	Page
Installation and Maintenance Requirements	34
Installation Guidelines	37
Top Hat Section Rail (DIN rail)	38
Assembling a Module to a Controller or Receiver Module	41
Disassembling a Module from a Controller or Receiver Module	43
Direct Mounting on a Panel Surface	44

## Installation and Maintenance Requirements

### Before Starting

Read and understand this chapter before beginning the installation of your system.

The use and application of the information contained herein require expertise in the design and programming of automated control systems. Only you, the user, machine builder or integrator, can be aware of all the conditions and factors present during installation and setup, operation, and maintenance of the machine or process, and can therefore determine the automation and associated equipment and the related safeties and interlocks which can be effectively and properly used. When selecting automation and control equipment, and any other related equipment or software, for a particular application, you must also consider any applicable local, regional or national standards and/or regulations.

Pay particular attention in conforming to any safety information, different electrical requirements, and normative standards that would apply to your machine or process in the use of this equipment.

### Disconnecting Power

All options and modules should be assembled and installed before installing the control system on a mounting rail, onto a mounting plate or in a panel. Remove the control system from its mounting rail, mounting plate or panel before disassembling the equipment.

## DANGER

### HAZARD OF ELECTRIC SHOCK, EXPLOSION OR ARC FLASH

- Disconnect all power from all equipment including connected devices prior to removing any covers or doors, or installing or removing any accessories, hardware, cables, or wires except under the specific conditions specified in the appropriate hardware guide for this equipment.
- Always use a properly rated voltage sensing device to confirm the power is off where and when indicated.
- Replace and secure all covers, accessories, hardware, cables, and wires and confirm that a proper ground connection exists before applying power to the unit.
- Use only the specified voltage when operating this equipment and any associated products.

**Failure to follow these instructions will result in death or serious injury.**

## Programming Considerations

### **WARNING**

#### **UNINTENDED EQUIPMENT OPERATION**

- Only use software approved by Schneider Electric for use with this equipment.
- Update your application program every time you change the physical hardware configuration.

**Failure to follow these instructions can result in death, serious injury, or equipment damage.**

## Operating Environment

This equipment has been designed to operate outside of any hazardous location. Only install this equipment in zones known to be free of a hazardous atmosphere.

### **DANGER**

#### **POTENTIAL FOR EXPLOSION**

Install and use this equipment in non-hazardous locations only.

**Failure to follow these instructions will result in death or serious injury.**

### **WARNING**

#### **UNINTENDED EQUIPMENT OPERATION**

Install and operate this equipment according to the conditions described in the Environmental Characteristics.

**Failure to follow these instructions can result in death, serious injury, or equipment damage.**

## Installation Considerations

### **WARNING**

#### **UNINTENDED EQUIPMENT OPERATION**

- Use appropriate safety interlocks where personnel and/or equipment hazards exist.
- Install and operate this equipment in an enclosure appropriately rated for its intended environment.
- Use the sensor and actuator power supplies only for supplying power to the sensors or actuators connected to the module.
- Power line and output circuits must be wired and fused in compliance with local and national regulatory requirements for the rated current and voltage of the particular equipment.
- Do not use this equipment in safety-critical machine functions.
- Do not disassemble, repair, or modify this equipment.
- Do not connect any wiring to reserved, unused connections, or to connections designated as No Connection (N.C.).

**Failure to follow these instructions can result in death, serious injury, or equipment damage.**

**NOTE:** JDYX2 or JDYX8 fuse types are UL-recognized and CSA approved.

## Installation Guidelines

### Introduction

TM3 expansion modules are assembled by connecting them to a logic controller or receiver module.

The logic controller or receiver module and their expansion modules can be installed on a top hat section rail (DIN rail).

### Mounting Position and Minimum Clearances

The mounting position and minimum clearances of the expansion modules must conform with the rules defined for the appropriate hardware system. Refer to the *Installation chapter* in the *Controller Hardware* documentation for your specific controller.

## WARNING

### UNINTENDED EQUIPMENT OPERATION

- Place devices dissipating the most heat at the top of the cabinet and ensure adequate ventilation.
- Avoid placing this equipment next to or above devices that might cause overheating.
- Install the equipment in a location providing the minimum clearances from all adjacent structures and equipment as directed in this document.
- Install all equipment in accordance with the specifications in the related documentation.

**Failure to follow these instructions can result in death, serious injury, or equipment damage.**

## Top Hat Section Rail (DIN rail)

### Dimensions of Top Hat Section Rail DIN Rail

You can mount the controller or receiver and its expansions on a 35 mm (1.38 in.) top hat section rail (DIN rail). It can be attached to a smooth mounting surface or suspended from a EIA rack or mounted in a NEMA cabinet.

### Symmetric Top Hat Section Rails (DIN Rail)

The following illustration and table show the references of the top hat section rails (DIN rail) for the wall-mounting range:

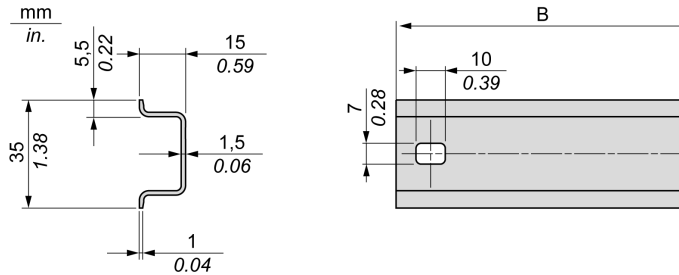

Reference	Type	Rail Length (B)
NSYSR50A	A	450 mm (17.71 in.)
NSYSR60A	A	550 mm (21.65 in.)
NSYSR80A	A	750 mm (29.52 in.)
NSYSR100A	A	950 mm (37.40 in.)

The following illustration and table show the references of the symmetric top hat section rails (DIN rail) for the metal enclosure range:

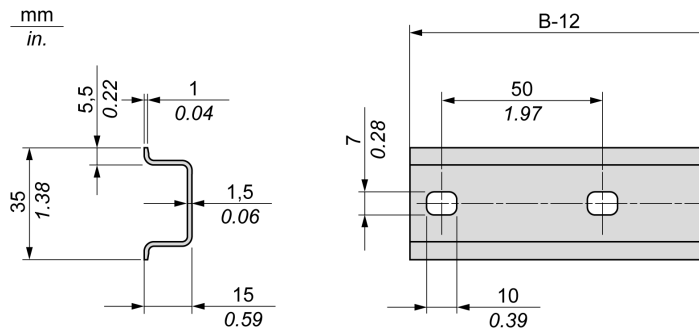

Reference	Type	Rail Length (B-12 mm)
NSYS DR60	A	588 mm (23.15 in.)
NSYS DR80	A	788 mm (31.02 in.)
NSYS DR100	A	988 mm (38.89 in.)
NSYS DR120	A	1188 mm (46.77 in.)

The following illustration and table shows the references of the symmetric top hat section rails (DIN rail) of 2000 mm (78.74 in.):

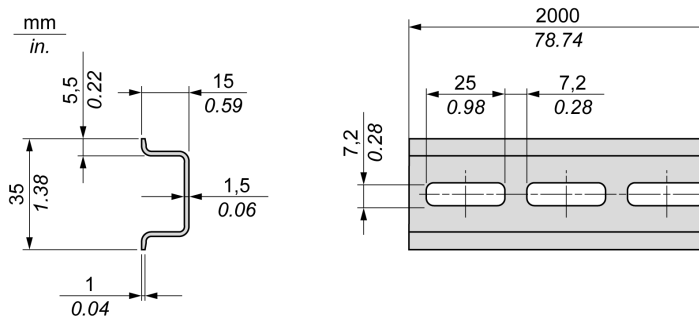

Reference	Type	Rail Length
NSYS DR200 <sup>1</sup>	A	2000 mm (78.74 in.)
NSYS DR200D <sup>2</sup>	A	
<b>1</b> Unperforated galvanized steel <b>2</b> Perforated galvanized steel		

### Double-Profile Top Hat Section Rails (DIN rail)

The following illustration and table show the references of the double-profile top hat section rails (DIN rails) for the wall-mounting range:

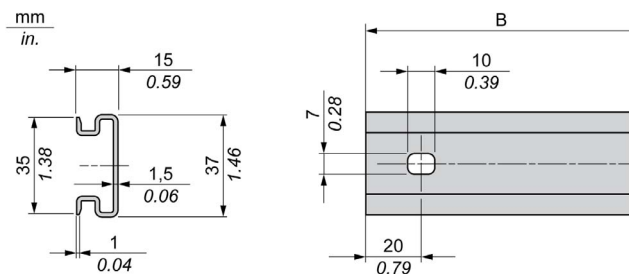

Reference	Type	Rail Length (B)
NSYDPR25	W	250 mm (9.84 in.)
NSYDPR35	W	350 mm (13.77 in.)
NSYDPR45	W	450 mm (17.71 in.)
NSYDPR55	W	550 mm (21.65 in.)
NSYDPR65	W	650 mm (25.60 in.)
NSYDPR75	W	750 mm (29.52 in.)

The following illustration and table show the references of the double-profile top hat section rails (DIN rail) for the floor-standing range:

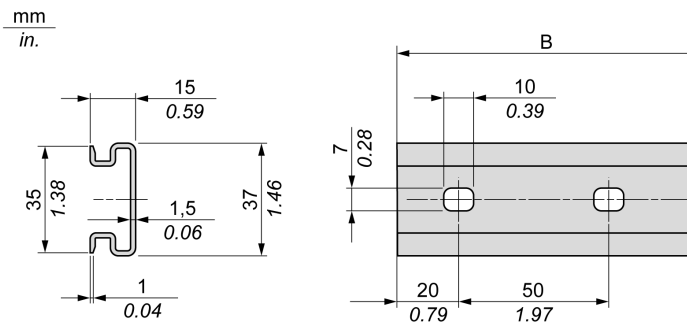

Reference	Type	Rail Length (B)
NSYDPR60	F	588 mm (23.15 in.)
NSYDPR80	F	788 mm (31.02 in.)
NSYDPR100	F	988 mm (38.89 in.)
NSYDPR120	F	1188 mm (46.77 in.)



## Assembling a Module to a Controller or Receiver Module

### Introduction

This section describes how to assemble an expansion module to a controller, Receiver module or other modules.

#### **DANGER**

##### **HAZARD OF ELECTRIC SHOCK, EXPLOSION OR ARC FLASH**

- Disconnect all power from all equipment including connected devices prior to removing any covers or doors, or installing or removing any accessories, hardware, cables, or wires except under the specific conditions specified in the appropriate hardware guide for this equipment.
- Always use a properly rated voltage sensing device to confirm the power is off where and when indicated.
- Replace and secure all covers, accessories, hardware, cables, and wires and confirm that a proper ground connection exists before applying power to the unit.
- Use only the specified voltage when operating this equipment and any associated products.

**Failure to follow these instructions will result in death or serious injury.**

After connecting new modules to the controller, either directly or through a transmitter/receiver, update and reupload your application program before placing the system back in service. If you do not revise your application program to reflect the addition of new modules, I/O located on the expansion bus may no longer operate normally.

#### **WARNING**

##### **UNINTENDED EQUIPMENT OPERATION**

- Only use software approved by Schneider Electric for use with this equipment.
- Update your application program every time you change the physical hardware configuration.

**Failure to follow these instructions can result in death, serious injury, or equipment damage.**

### Assembling a Module to a Controller or Receiver Module

The following procedure shows how to assemble a controller or receiver module and a module together.

Step	Action
1	Remove all power and dismount any existing controller I/O assembly from its DIN mounting.
2	Remove the expansion connector sticker from the controller or the outermost installed expansion module.
3	Verify that the locking device on the new module is in the upper position.
4	Align the internal bus connector on the left side of the module with the internal bus connector on the right side of the controller, Receiver module or expansion module.
5	Press the new module towards the controller, Receiver module or expansion module until it is securely in place.
6	Push down the locking device on the top of the new module to lock it to the controller, Receiver module or previously installed expansion module.

## Disassembling a Module from a Controller or Receiver Module

### Introduction

This section describes how to disassemble a module from a controller or receiver module.



#### HAZARD OF ELECTRIC SHOCK, EXPLOSION OR ARC FLASH

- Disconnect all power from all equipment including connected devices prior to removing any covers or doors, or installing or removing any accessories, hardware, cables, or wires except under the specific conditions specified in the appropriate hardware guide for this equipment.
- Always use a properly rated voltage sensing device to confirm the power is off where and when indicated.
- Replace and secure all covers, accessories, hardware, cables, and wires and confirm that a proper ground connection exists before applying power to the unit.
- Use only the specified voltage when operating this equipment and any associated products.

**Failure to follow these instructions will result in death or serious injury.**

### Disassembling a Module from a Controller or Receiver Module

The following procedure describes how to disassemble a module from a controller or receiver module.

Step	Action
1	Remove all power from the control system.
2	Dismount the assembled controller and modules from the mounting rail.
3	Push up the locking device ( <i>see page 20</i> ) from the bottom of the module to disengage it from the controller or receiver module.
4	Pull apart module from the controller or receiver module.

## Direct Mounting on a Panel Surface

### Overview

This section shows how to install TM3 expansion module using the Panel Mounting Kit. This section also provides mounting hole layout for all modules.

### Installing the Panel Mount Kit

The following procedure shows how to install a mounting strip:

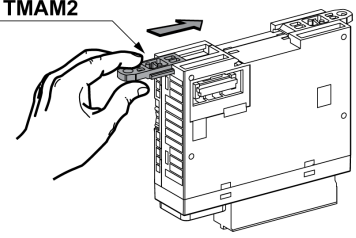
Step	Action
1	Insert the mounting strip TMAM2 into the slot at the top of the module. 

### Mounting Hole Layout

The following diagram shows the mounting holes for TM3 with 8 I/Os ,16 I/Os ,TM3XTRA1 , TM3XREC1 and TM3XTYS4 expansion modules:

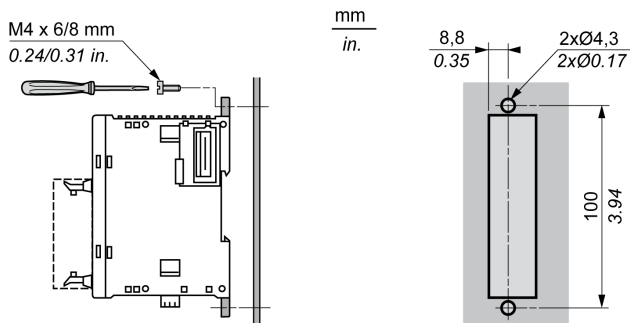

The following diagram shows the mounting holes for TM3 with 24 screw or spring I/O channels:

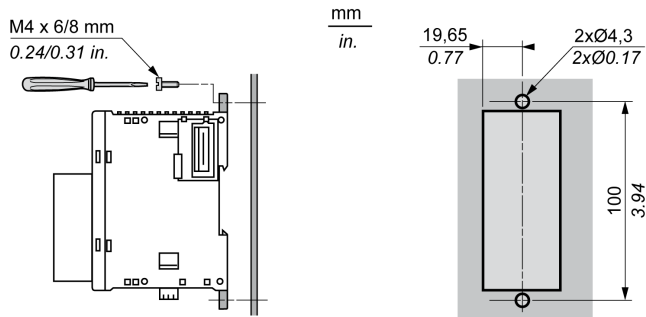

The following diagram shows the mounting holes for TM3 with 32 HE10 (MIL 20) I/O channels:

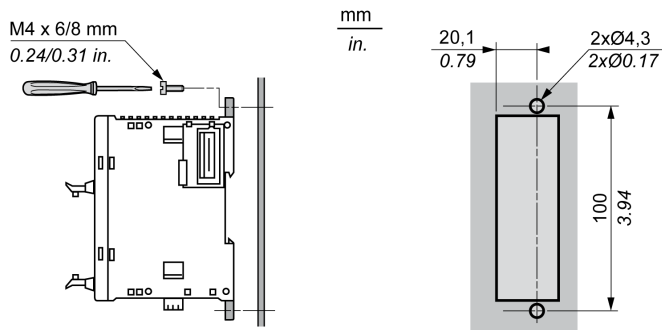

# Section 2.3

## TM3 Electrical Requirements

---

### What Is in This Section?

This section contains the following topics:

Topic	Page
Wiring Best Practices	47
DC Power Supply Characteristics	53

## Wiring Best Practices

### Overview

This section describes the wiring guidelines and associated best practices to be respected when using the TM3 system.

### DANGER

#### HAZARD OF ELECTRIC SHOCK, EXPLOSION OR ARC FLASH

- Disconnect all power from all equipment including connected devices prior to removing any covers or doors, or installing or removing any accessories, hardware, cables, or wires except under the specific conditions specified in the appropriate hardware guide for this equipment.
- Always use a properly rated voltage sensing device to confirm the power is off where and when indicated.
- Replace and secure all covers, accessories, hardware, cables, and wires and confirm that a proper ground connection exists before applying power to the unit.
- Use only the specified voltage when operating this equipment and any associated products.

**Failure to follow these instructions will result in death or serious injury.**

### WARNING

#### LOSS OF CONTROL

- The designer of any control scheme must consider the potential failure modes of control paths and, for certain critical control functions, provide a means to achieve a safe state during and after a path failure. Examples of critical control functions are emergency stop and overtravel stop, power outage and restart.
- Separate or redundant control paths must be provided for critical control functions.
- System control paths may include communication links. Consideration must be given to the implications of unanticipated transmission delays or failures of the link.
- Observe all accident prevention regulations and local safety guidelines.<sup>1</sup>
- Each implementation of this equipment must be individually and thoroughly tested for proper operation before being placed into service.

**Failure to follow these instructions can result in death, serious injury, or equipment damage.**

<sup>1</sup> For additional information, refer to NEMA ICS 1.1 (latest edition), "Safety Guidelines for the Application, Installation, and Maintenance of Solid State Control" and to NEMA ICS 7.1 (latest edition), "Safety Standards for Construction and Guide for Selection, Installation and Operation of Adjustable-Speed Drive Systems" or their equivalent governing your particular location.

### Functional Ground (FE) on the DIN Rail

The DIN Rail for your TM3 system is common with the functional ground (FE) plane and must be mounted on a conductive backplane.

## **WARNING**

### **UNINTENDED EQUIPMENT OPERATION**

Connect the DIN rail to the functional ground (FE) of your installation.

**Failure to follow these instructions can result in death, serious injury, or equipment damage.**

### Protective Ground (PE) on the Backplane

The protective ground (PE) is connected to the conductive backplane by a heavyduty wire, usually a braided copper cable with the maximum allowable cable section.

### Wiring Guidelines

The following rules must be applied when wiring a TM3 system:

- I/O and communication wiring must be kept separate from the power wiring. Route these 2 types of wiring in separate cable ducting.
- Verify that the operating conditions and environment are within the specification values.
- Use proper wire sizes to meet voltage and current requirements.
- Use copper conductors (highly recommended).
- Use twisted-pair, shielded cables for analog, and/or fast I/O.
- Use twisted-pair, shielded cables for networks, and field bus.

## **WARNING**

### **UNINTENDED EQUIPMENT OPERATION**

- Use shielded cables for all fast I/O, analog I/O, and communication signals.
- Ground cable shields for all fast I/O, analog I/O, and communication signals at a single point<sup>1</sup>.
- Route communications and I/O cables separately from power cables.

**Failure to follow these instructions can result in death, serious injury, or equipment damage.**







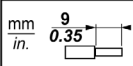

<sup>1</sup>Multipoint grounding is permissible if connections are made to an equipotential ground plane dimensioned to help avoid cable shield damage in the event of power system short-circuit currents.

**NOTE:** Surface temperatures may exceed 60° C. To conform to IEC 61010 standards, route primary wiring (wires connected to power mains) separately and apart from secondary wiring (extra low voltage wiring coming from intervening power sources). If that is not possible, double insulation is required such as conduit or cable gains.





### Rules for Removable Screw Terminal Block







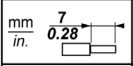

The following tables show the cable types and wire sizes for a **3.81 pitch** removable screw terminal block (I/Os and power supply):

								
mm <sup>2</sup>	0.14...1.5	0.14...1.5	0.25...1.5	0.25...0.5	2 x 0.14...0.5	2 x 0.14...0.75	2 x 0.25...0.34	2 x 0.5
AWG	25...16	25...16	23...16	23...20	2 x 25...20	2 x 25...19	2 x 24...22	2 x 20



  

		N•m	0.22...0.25
Ø 2,5 mm (0.1 in.)		lb-in	1.95...2.21

The following tables show the cable types and wire sizes for a **5.08 pitch** removable screw terminal block (I/Os and power supply):

								
mm <sup>2</sup>	0.2...2.5	0.2...2.5	0.25...2.5	0.25...2.5	2 x 0.2...1	2 x 0.2...1.5	2 x 0.25...1	2 x 0.5...1.5
AWG	24...14	24...14	23...14	23...14	2 x 24...17	2 x 24...16	2 x 23...17	2 x 20...16

		N•m	0.5...0.6
Ø 3,5 mm (0.14 in.)		lb-in	4.42...5.31

The use of copper conductors is required.

 **DANGER**

**FIRE HAZARD**

- Use only the recommended wire sizes for the current capacity of the I/O channels and power supplies.
- For relay output (2 A) wiring, use conductors of at least 0.5 mm<sup>2</sup> (AWG 20) with a temperature rating of at least 80 °C (176 °F).
- For common conductors of relay output wiring (7 A), or relay output wiring greater than 2 A, use conductors of at least 1.0 mm<sup>2</sup> (AWG 16) with a temperature rating of at least 80 °C (176 °F).

**Failure to follow these instructions will result in death or serious injury.**

### Rules for Removable Spring Terminal Block

The following tables show the cable types and wire sizes for a **3.81 pitch** removable spring terminal block (I/Os and power supply):

$\frac{\text{mm}}{\text{in.}}$ 9 0.35				
mm <sup>2</sup>	0.2...1.5	0.2...1.5	0.25...1.5	0.25...0.75
AWG	24...16	24...16	23...16	23...19

The following tables show the cable types and wire sizes for a **5.08 pitch** removable spring terminal block (I/Os and power supply):

$\frac{\text{mm}}{\text{in.}}$ 10 0.39					
mm <sup>2</sup>	0.2...2.5	0.2...2.5	0.25...2.5	0.25...2.5	2 x 0.5...1
AWG	24...14	24...14	23...14	23...14	2 x 20...17

The use of copper conductors is required.

## ⚠ DANGER

### FIRE HAZARD

- Use only the recommended wire sizes for the current capacity of the I/O channels and power supplies.
- For relay output (2 A) wiring, use conductors of at least 0.5 mm<sup>2</sup> (AWG 20) with a temperature rating of at least 80 °C (176 °F).
- For common conductors of relay output wiring (7 A), or relay output wiring greater than 2 A, use conductors of at least 1.0 mm<sup>2</sup> (AWG 16) with a temperature rating of at least 80 °C (176 °F).

**Failure to follow these instructions will result in death or serious injury.**

The spring clamp connectors of the terminal block are designed for only one wire or one cable end. Two wires to the same connector must be installed with a double wire cable end to help prevent loosening.

## ⚠ DANGER

### LOOSE WIRING CAUSES ELECTRIC SHOCK

Do not insert more than one wire per connector of the terminal block without a double wire cable end.

**Failure to follow these instructions will result in death or serious injury.**

## Protecting Outputs from Inductive Load Damage

Depending on the load, a protection circuit may be needed for the outputs on the controllers and certain modules. Inductive loads using DC voltages may create voltage reflections resulting in overshoot that will damage or shorten the life of output devices.

### ⚠ CAUTION

#### OUTPUT CIRCUIT DAMAGE DUE TO INDUCTIVE LOADS

Use an appropriate external protective circuit or device to reduce the risk of inductive direct current load damage.

**Failure to follow these instructions can result in injury or equipment damage.**

If your controller or module contains relay outputs, these types of outputs can support up to 240 Vac. Inductive damage to these types of outputs can result in welded contacts and loss of control. Each inductive load must include a protection device such as a peak limiter, RC circuit or flyback diode. Capacitive loads are not supported by these relays.

### ⚠ WARNING

#### RELAY OUTPUTS WELDED CLOSED

- Always protect relay outputs from inductive alternating current load damage using an appropriate external protective circuit or device.
- Do not connect relay outputs to capacitive loads.

**Failure to follow these instructions can result in death, serious injury, or equipment damage.**

Protective circuit A: this protection circuit can be used for both AC and DC load power circuits.

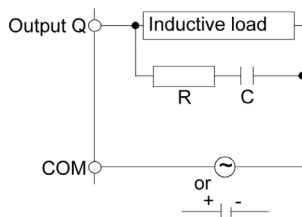

- C represents a value from 0.1 to 1  $\mu\text{F}$ .
- R represents a resistor of approximately the same resistance value as the load.

Protective circuit B: this protection circuit can be used for DC load power circuits.

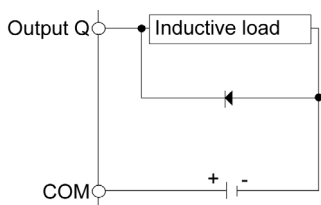

Use a diode with the following ratings:

- Reverse withstand voltage: power voltage of the load circuit x 10.
- Forward current: more than the load current.

Protective circuit C: this protection circuit can be used for both AC and DC load power circuits.

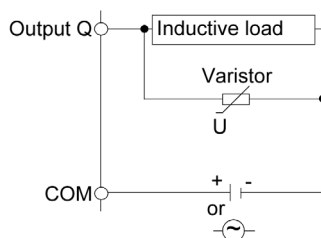

- In applications where the inductive load is switched on and off frequently and/or rapidly, ensure that the continuous energy rating (J) of the varistor exceeds the peak load energy by 20 % or more.

## DC Power Supply Characteristics

### Overview

This section provides the characteristics of the DC power supply.

### Power Supply Voltage Range

If the specified voltage range is not maintained, outputs may not switch as expected. Use appropriate safety interlocks and voltage monitoring circuits.

## DANGER

### FIRE HAZARD

- Use only the recommended wire sizes for the current capacity of the I/O channels and power supplies.
- For relay output (2 A) wiring, use conductors of at least 0.5 mm<sup>2</sup> (AWG 20) with a temperature rating of at least 80 °C (176 °F).
- For common conductors of relay output wiring (7 A), or relay output wiring greater than 2 A, use conductors of at least 1.0 mm<sup>2</sup> (AWG 16) with a temperature rating of at least 80 °C (176 °F).

**Failure to follow these instructions will result in death or serious injury.**

## WARNING

### UNINTENDED EQUIPMENT OPERATION

Do not exceed any of the rated values specified in the environmental and electrical characteristics tables.

**Failure to follow these instructions can result in death, serious injury, or equipment damage.**

## DC Power Supply Characteristics

The 24 Vdc power supplies must be rated Safety Extra Low Voltage (SELV) or Protective Extra Low Voltage (PELV) according to IEC 61140. These power supplies are isolated between the electrical input and output circuits of the power supply.

### WARNING

#### POTENTIAL OF OVERHEATING AND FIRE

- Do not connect the equipment directly to line voltage.
- Use only isolating PELV or SELV power supplies to supply power to the equipment<sup>1</sup>.

**Failure to follow these instructions can result in death, serious injury, or equipment damage.**

<sup>1</sup>For compliance to UL (Underwriters Laboratories) requirements, the power supply must also be of a type Class II with a maximum power output availability of less than 100 VA (approximately 4 A at nominal voltage). A Class II circuit requires dry indoor use only in non-hazardous locations, and must be grounded. You must separate Class II circuits from other circuits. If a non-Class II power source is used, either power supply or transformer, you must impose a current limiting device such as a fuse or a circuit breaker with a maximum rating of 4 A, but never exceeding the limits indicated in the electric characteristics and wiring diagrams for this equipment. If the indicated rating of the electrical characteristics or wiring diagrams are greater than 4 A, multiple Class II power supplies may be used.

---

# Part II

## TM3 Digital Input Modules

---

### What Is in This Part?

This part contains the following chapters:

Chapter	Chapter Name	Page
3	TM3DI8A Module 8 Inputs 120 Vac	57
4	TM3DI8 / TM3DI8G Module 8 Regular Inputs 24 Vdc	63
5	TM3DI16 / TM3DI16G Module 16 Regular Inputs 24 Vdc	69
6	TM3DI16K Module 16 Regular Inputs 24 Vdc	77
7	TM3DI32K Module 32 Regular Inputs 24 Vdc	85





---

# Chapter 3

## TM3DI8A Module 8 Inputs 120 Vac

---

### Overview

This chapter describes the TM3DI8A expansion modules, its characteristics, and its connection to the different sensors.

### What Is in This Chapter?

This chapter contains the following topics:

Topic	Page
TM3DI8A Presentation	58
TM3DI8A Characteristics	59
TM3DI8A Wiring Diagram	61

## TM3DI8A Presentation

### Overview

TM3DI8A (screw) digital expansion module:

- 8 channels
- 120 Vac digital input
- 2 common lines
- removable screw terminal block

### Main Characteristics

Characteristic		Value
Number of input channels		8
Input type		Type 1 (IEC/EN 61131-2)
Logic type		N/A
Rated input voltage		120 Vac
Connection type		Removable screw terminal block
Cable type and length	Type	stranded wire 2,5 mm <sup>2</sup>
	Length	-

### Status LEDs

The following figure shows the status LEDs:



This table describes the status LEDs:

LED	Color	Status	Description
0...7	Green	On	The input channel is activated.
		Off	The input channel is deactivated.

## TM3DI8A Characteristics

### Introduction

This section provides a general description of the characteristics of the TM3DI8A expansion module.

See also Environmental Characteristics ([see page 29](#)).

### WARNING

#### UNINTENDED EQUIPMENT OPERATION

Do not exceed any of the rated values specified in the environmental and electrical characteristics tables.

**Failure to follow these instructions can result in death, serious injury, or equipment damage.**

### Dimensions

The following diagrams show the external dimensions for the TM3DI8A module:

$\frac{\text{mm}}{\text{in.}}$

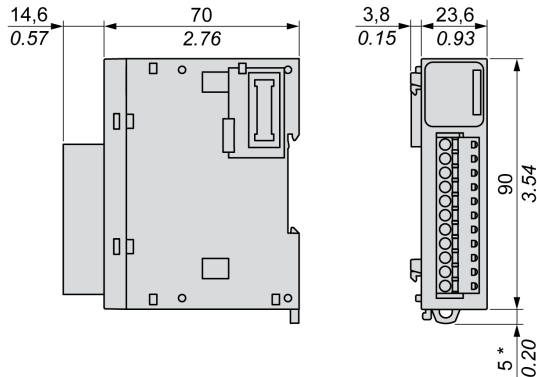

\* 8.5 mm (0.33 in.) when the clamp is pulled out.

### Input Characteristics

The table below describes the inputs characteristics of the TM3DI8A expansion module:

Characteristic		Value
Number of input channels		8 inputs
Number of channels groups		2 common lines of 4 channels each
Input type		Type 1 (IEC/EN 61131-2))
Logic type		N/A
Rated input voltage		120 Vac
Input voltage range		0...132 Vac
Rated input current		7.5 mA at 100 Vac
Input impedance		11 kΩ
Turn on time		25 ms
De-rating	-10...55 °C (14...131 °F)	No de-rating
Input limit values	Voltage at state 1	> 79 Vac (79...132 Vac)
	Voltage at state 0	< 20 Vac (0...20 Vac)
	Current at state 1	2 mA < I < 15 mA
	Current at state 0	0 mA < I < 15 mA
Isolation	Between input and internal logic	1500 Vac
	Between input groups	1500 Vac
Connector type		Removable screw terminal block
Connector insertion/removal durability		Over 100 times
Current draw on 5 Vdc internal bus		70 mA (all inputs on)
		25 mA (all inputs off)
Current draw on 24 Vdc internal bus		0 mA (all inputs on)
		0 mA (all inputs off)

## TM3DI8A Wiring Diagram

### Introduction

This expansion module has a built-in removable screw terminal block for the connection of inputs and power supply.

### Wiring Rules

See Wiring Best Practices ([see page 47](#)).

### Wiring Diagram

The following figure illustrates the connection between the inputs, the sensors, and their commons:

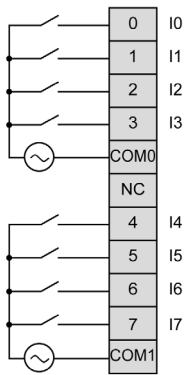

The COM0 and COM1 terminal are **not** connected internally.

## WARNING

### UNINTENDED EQUIPMENT OPERATION

Do not connect wires to unused terminals and/or terminals indicated as “No Connection (N.C.)”.

**Failure to follow these instructions can result in death, serious injury, or equipment damage.**



---

# Chapter 4

## TM3DI8 / TM3DI8G Module 8 Regular Inputs 24 Vdc

---

### Overview

This chapter describes the TM3DI8 / TM3DI8G expansion modules, its characteristics and its connection to the different sensors.

### What Is in This Chapter?

This chapter contains the following topics:

Topic	Page
TM3DI8 / TM3DI8G Presentation	64
TM3DI8 / TM3DI8G Characteristics	66
TM3DI8 / TM3DI8G Wiring Diagram	68

## TM3DI8 / TM3DI8G Presentation

### Overview

TM3DI8 (screw) and TM3DI8G (spring) digital expansion module:

- 8 channels
- 24 Vdc digital input
- 1 common line
- Sink/source
- removable screw or spring terminal block

### Main Characteristics

Characteristic		Value
Number of input channels		8 inputs
Input type		Type 1 (IEC/EN 61131-2)
Logic type		Sink/Source
Rated input voltage		24 Vdc
Connection type	TM3DI8	Removable screw terminal block
	TM3DI8G	Removable spring terminal block
Cable type and length	Type	Unshielded
	Length	Max. 30 m (98 ft)
Weight		85g (3 oz)



## Status LEDs

The following figure shows the status LEDs:

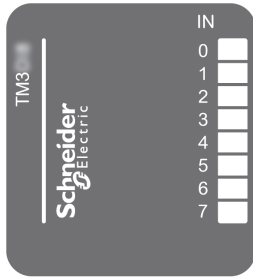

This table describes the status LEDs:

LED	Color	Status	Description
0...7	Green	On	The input channel is activated
		Off	The input channel is deactivated

## TM3DI8 / TM3DI8G Characteristics

### Introduction

This section provides a description of the input characteristics of TM3DI8 / TM3DI8G expansion modules.

See also Environmental Characteristics ([see page 29](#)).

### **⚠ WARNING**

#### **UNINTENDED EQUIPMENT OPERATION**

Do not exceed any of the rated values specified in the environmental and electrical characteristics tables.

**Failure to follow these instructions can result in death, serious injury, or equipment damage.**

### Dimensions

The following diagrams show the external dimensions for the TM3DI8 / TM3DI8G expansion modules:

$\frac{\text{mm}}{\text{in.}}$

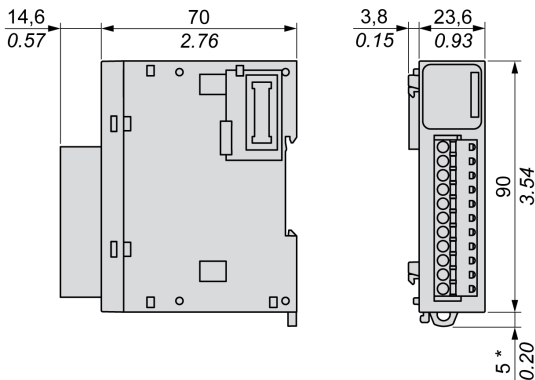

\* 8.5 mm (0.33 in.) when the clamp is pulled out.

## Input Characteristics

The table below describes the inputs characteristics of the TM3DI8 / TM3DI8G:

Characteristic		Value
Number of input channels		8 inputs
Number of channels groups		1 common line on three terminals for 8 channels
Input type		Type 1 (IEC/EN 61131-2)
Logic type		Sink/Source
Rated input voltage		24 Vdc
Input voltage range		19.2...28.8 Vdc
Rated input current		7 mA
Input impedance		3.4 k $\Omega$
Turn on time		4 ms
Turn off time		4 ms
De-rating	-10...55 °C (14...131 °F)	No de-rating
Input limit values	Voltage at state 1	> 15 Vdc (15...28.8 Vdc)
	Voltage at state 0	< 5 Vdc (0...5 Vdc)
	Current at state 1	> 2.5 mA
	Current at state 0	<1 mA
Isolation	Between input and internal logic	500 Vac
	Between input groups	N/A
Connection type	TM3DI8	Removable screw terminal block
	TM3DI8G	Removable spring terminal block
Connector insertion/removal durability		Over 100 times
Current draw on 5 Vdc internal bus		24 mA (all inputs on)
		5 mA (all inputs off)
Current draw on 24 Vdc internal bus		0 mA (all inputs on)
		0 mA (all inputs off)

## TM3DI8 / TM3DI8G Wiring Diagram

### Introduction

These expansion modules have a built-in removable screw or spring terminal block for the connection of inputs and power supply.

### Wiring Rules

See Wiring Best Practices ([see page 47](#)).

### Wiring Diagram

The following figure illustrates the connection between the inputs, the sensors, and their commons:

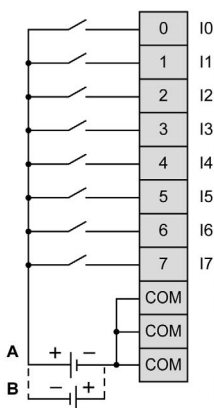

The 3 COM terminals are connected internally.

- A** Sink wiring (positive logic)
- B** Source wiring (negative logic)

For information about 24 Vdc power supply, refer to DC Power Supply Characteristics ([see page 53](#)).

---

# Chapter 5

## TM3DI16 / TM3DI16G Module 16 Regular Inputs 24 Vdc

---

### Overview

This chapter describes the TM3DI16 / TM3DI16G expansion modules, its characteristics and its connection to the different sensors.

### What Is in This Chapter?

This chapter contains the following topics:

Topic	Page
TM3DI16 / TM3DI16G Presentation	70
TM3DI16 / TM3DI16G Characteristics	72
TM3DI16 / TM3DI16G Wiring Diagrams	75

## TM3DI16 / TM3DI16G Presentation

### Overview

TM3DI16 (screw) and TM3DI16G (spring) digital expansion module:

- 16 channels
- 24 Vdc digital input
- 1 common line
- Sink/source
- Removable screw or spring terminal block

### Main Characteristics

Characteristic		Value
Number of input channels		16
Input type		Type 1 (IEC/EN 61131-2)
Logic type		Sink/Source
Rated input voltage		24 Vdc
Connection type	TM3DI16	Removable screw terminal blocks
	TM3DI16G	Removable spring terminal blocks
Cable type and length	Type	Unshielded
	Length	Max. 30 m (98 ft)
Weight		100 g (3.52 oz)

## Status LEDs

The following figure show the status LEDs:



This table describes the status LEDs:

LED	Color	Status	Description
0...15	Green	On	The input channel is activated
		Off	The input channel is deactivated

## TM3DI16 / TM3DI16G Characteristics

### Introduction

This section provides a description of the input characteristics of TM3DI16 / TM3DI16G expansion modules.

See also Environmental Characteristics ([see page 29](#)).

### **⚠ WARNING**

#### **UNINTENDED EQUIPMENT OPERATION**

Do not exceed any of the rated values specified in the environmental and electrical characteristics tables.

**Failure to follow these instructions can result in death, serious injury, or equipment damage.**

### Dimensions

The following diagrams show the external dimensions for the TM3DI16 / TM3DI16G expansion modules:

mm  
in.

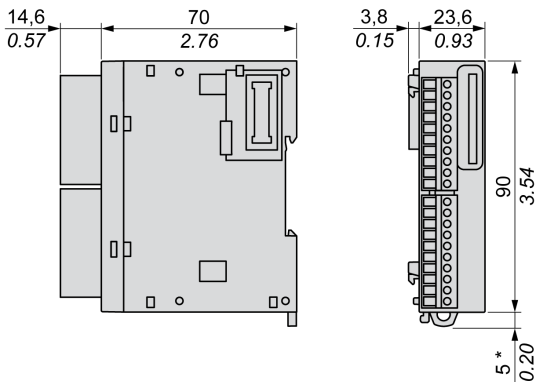

\* 8.5 mm (0.33 in.) when the clamp is pulled out.



## Input Characteristics

The table below describes the inputs characteristics of the TM3DI16 / TM3DI16G:

Characteristic		Value
Number of input channels		16 inputs
Number of channels groups		1 common line on 4 terminals (2 per connector) for 16 channels
Input type		Type 1 (IEC/EN 61131-2)
Logic type		Sink/Source
Rated input voltage		24 Vdc
Input voltage range		19.2...28.8 Vdc
Rated input current		7 mA
Input impedance		3.4 k $\Omega$
Input limit values	Voltage at state 1	> 15 Vdc (15...28.8 Vdc)
	Voltage at state 0	< 5 Vdc (0...5 Vdc)
	Current at state 1	> 2.5 mA
	Current at state 0	<1 mA
Turn on time		4 ms
Turn off time		4 ms
Isolation	Between input and internal logic	500 Vac
	Between input groups	N/A
Connection type	TM3DI16	Removable screw terminal blocks
	TM3DI16G	Removable spring terminal blocks
Connector insertion/removal durability		Over 100 times
Current draw on 5 Vdc internal bus		40 mA (all inputs on) 5 mA (all inputs off)
Current draw on 24 Vdc internal bus		0 mA (all inputs on) 0 mA (all inputs off)

### I/O Re-rating

When using TM3DI16 / TM3DI16G:

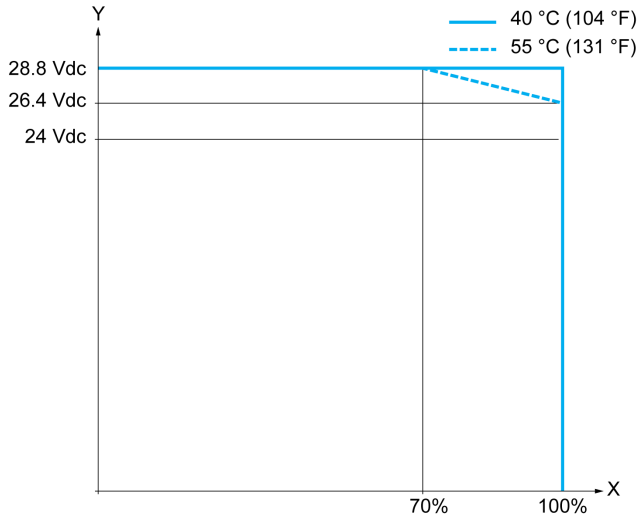

**X** Input simultaneous ON ratio  
**Y** Input voltage

## TM3DI16 / TM3DI16G Wiring Diagrams

### Introduction

These expansion modules have a built-in removable screw or spring terminal block for the connection of inputs and power supply.

### Wiring Rules

See Wiring Best Practices ([see page 47](#)).

### Wiring Diagrams

The following figure illustrates the connection between the inputs, the sensors, and their commons:

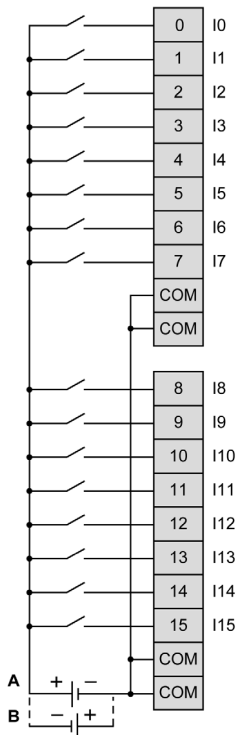

The 4 COM terminals are connected internally

- A** Sink wiring (positive logic)
- B** Source wiring (negative logic)

For information about 24 Vdc power supply, refer to DC Power Supply Characteristics ([see page 53](#)).



---

# Chapter 6

## TM3DI16K Module 16 Regular Inputs 24 Vdc

---

### Overview

This chapter describes the TM3DI16K expansion module, its characteristics and its connection to the different sensors.

### What Is in This Chapter?

This chapter contains the following topics:

Topic	Page
TM3DI16K Presentation	78
TM3DI16K Characteristics	80
TM3DI16K Wiring Diagrams	83

## TM3DI16K Presentation

### Overview

TM3DI16K (HE10) digital expansion module:

- 16 channels
- 24 Vdc digital input
- 1 common line
- Sink/source
- HE10 (MIL 20) connector

### Main Characteristics

Characteristic		Value
Number of input channels		16
Input type		Type 1 (IEC/EN 61131-2)
Logic type		Sink/Source
Rated input voltage		24 Vdc
Connection type		HE10 (MIL 20) connector
Cable type and length	Type	Unshielded
	Length	Max. 30 m (98 ft)
Weight		65 g (2.30 oz)

### Status LEDs

The following figure show the status LEDs:

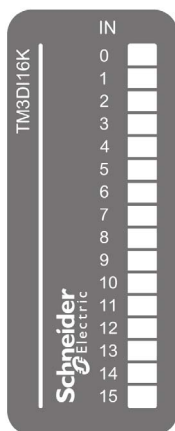

This table describes the status LEDs:

LED	Color	Status	Description
0...15	Green	On	The input channel is activated
		Off	The input channel is deactivated

## TM3DI16K Characteristics

### Introduction

This section provides a description of the input characteristics of TM3DI16K expansion module. See also Environmental Characteristics ([see page 29](#)).

## ⚠ WARNING

### UNINTENDED EQUIPMENT OPERATION

Do not exceed any of the rated values specified in the environmental and electrical characteristics tables.

**Failure to follow these instructions can result in death, serious injury, or equipment damage.**

### Dimensions

The following diagrams show the external dimensions for the TM3DI16K expansion module:

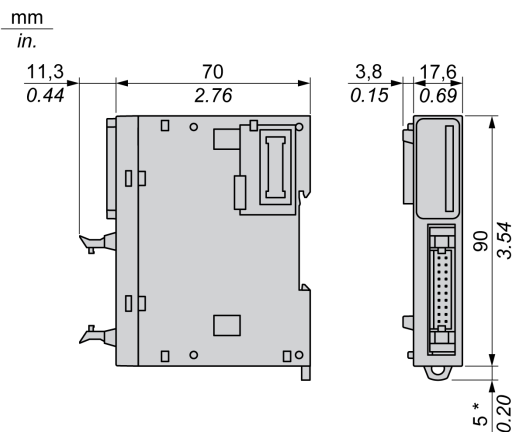

\* 8.5 mm (0.33 in.) when the clamp is pulled out.



## Input Characteristics

The table below describes the inputs characteristics of the TM3DI16K:

Characteristic		Value
Number of input channels		16 inputs
Number of channels groups		1 common line on 2 pins for 16 channels
Input type		Type 1 (IEC/EN 61131-2)
Logic type		Sink/Source
Rated input voltage		24 Vdc
Input voltage range		19.2...28.8 Vdc
Rated input current		5 mA
Input impedance		4.4 k $\Omega$
Input limit values	Voltage at state 1	> 15 Vdc (15...28.8 Vdc)
	Voltage at state 0	< 5 Vdc (0...5 Vdc)
	Current at state 1	> 2.5 mA
	Current at state 0	<1 mA
Turn on time		4 ms
Turn off time		4 ms
Isolation	Between input and internal logic	500 Vac
	Between input groups	N/A
Connection type		HE10 (MIL 20) connector
Connector insertion/removal durability		Over 100 times
Current draw on 5 Vdc internal bus		35 mA (all inputs on) 5 mA (all inputs off)
Current draw on 24 Vdc internal bus		0 mA (all inputs on) 0 mA (all inputs off)

### I/O Re-rating

When using TM3DI16K:

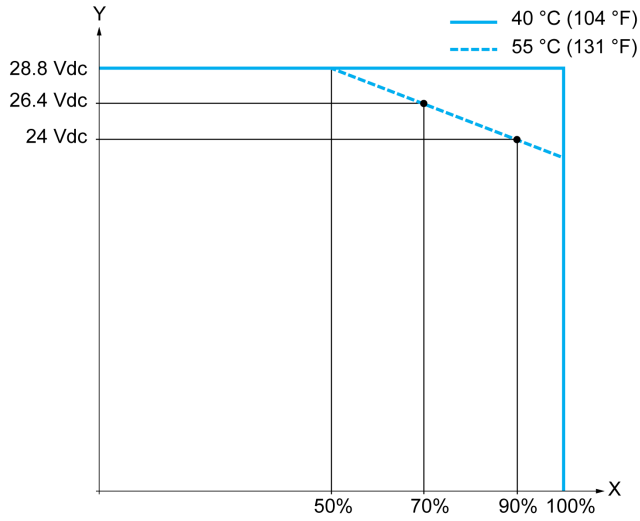

**X** Input simultaneous ON ratio  
**Y** Input voltage

## TM3DI16K Wiring Diagrams

### Introduction

This expansion module has a built-in HE10 (MIL 20) connector for the connection of inputs and power supply.

### Wiring Rules

See Wiring Best Practices ([see page 47](#)).

### Wiring Diagram with Free-Wire Cables

The following figure illustrates the connection between the inputs, the sensors, and their commons:

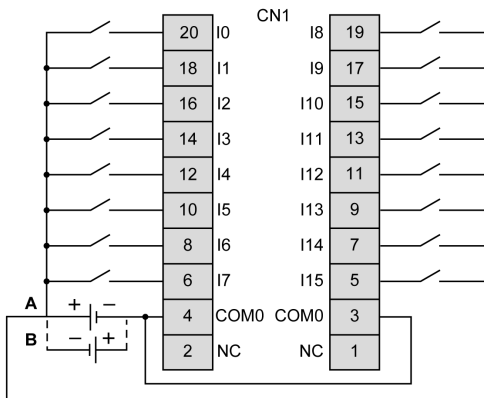

The COM0 terminals are connected internally

- A** Sink wiring (positive logic)
- B** Source wiring (negative logic)

For information about 24 Vdc power supply, refer to DC Power Supply Characteristics ([see page 53](#)).

For more information on the cable color for TWDFCW30K/TWDFCW50K, refer to TWDFCW••K Cable Description.

### Wiring Diagram with Telefast ABE7E16EPN20 Pre-Wiring Sub-base

The following figure shows the ABE7E16EPN20 sub-base:

TM221M32TK  
TM221ME32TK

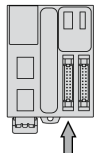

ABFT20E●●●



ABE7E16EPN20

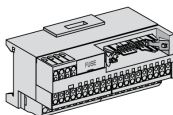

TM3DI16K  
TM3DI32K

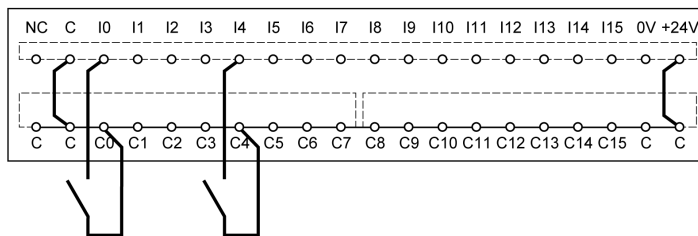
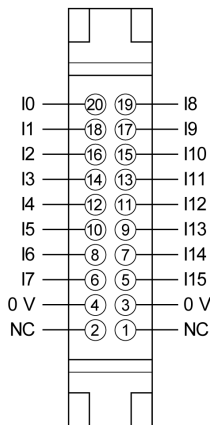
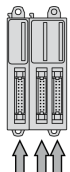

For more information on the Telefast cable, refer to Telefast Pre-wiring Sub-bases ([see page 24](#)).

---

# Chapter 7

## TM3DI32K Module 32 Regular Inputs 24 Vdc

---

### Overview

This chapter describes the TM3DI32K expansion module, its characteristics, and its connection to the different sensors.

### What Is in This Chapter?

This chapter contains the following topics:

Topic	Page
TM3DI32K Presentation	86
TM3DI32K Characteristics	88
TM3DI32K Wiring Diagram	91

## TM3DI32K Presentation

### Overview

TM3DI32K (HE10) digital expansion module:

- 32 channels
- 24 Vdc digital input
- 2 common lines
- Sink/source
- HE10 (MIL 20) connector

### Main Characteristics

Characteristic		Value
Number of input channels		32
Input type		Type 1 (IEC/EN 61131-2)
Logic type		Sink/Source
Rated input voltage		24 Vdc
Connection type		HE10 (MIL 20) connectors
Cable type and length	Type	Unshielded
	Length	Max. 30 m (98 ft)
Weight		100 g (3.52 oz)

### Status LEDs

The following figure shows the status LEDs:

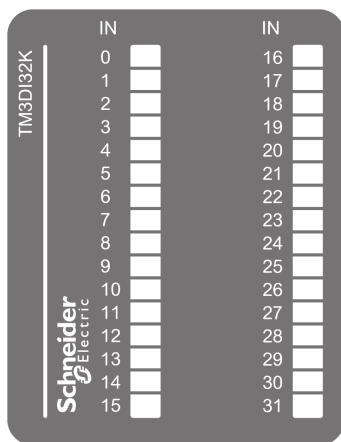

This table describes the status LEDs:

LED	Color	Status	Description
0...31	Green	On	The input channel is activated
		Off	The input channel is deactivated

## TM3DI32K Characteristics

### Introduction

This section provides a description of the input characteristics of the TM3DI32K expansion module. See also Environmental Characteristics ([see page 29](#)).

## ⚠ WARNING

### UNINTENDED EQUIPMENT OPERATION

Do not exceed any of the rated values specified in the environmental and electrical characteristics tables.

**Failure to follow these instructions can result in death, serious injury, or equipment damage.**

### Dimensions

The following diagrams show the external dimensions for the TM3DI32K expansion module:

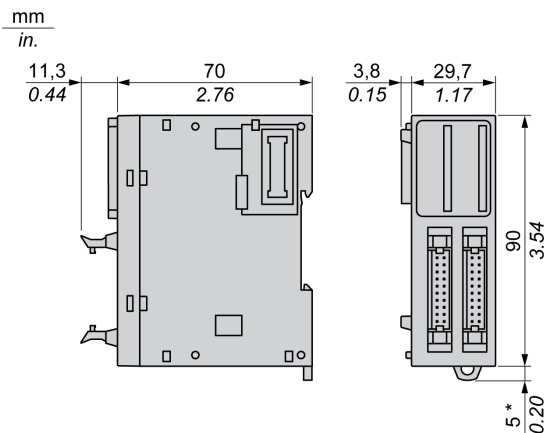

**NOTE:** \* 8.5 mm (0.33 in) when the clamp is pulled out.



## Input Characteristics

The table below describes the inputs characteristics of the TM3DI32K:

Characteristic		Value
Number of input channels		32 inputs
Number of channels groups		2 groups of 16, 1 common line each on 2 pins
Input type		Type 1 (IEC/EN 61131-2)
Logic type		Sink/Source
Rated input voltage		24 Vdc
Input voltage range		19.2...28.8 Vdc
Rated input current		5 mA
Input impedance		4.4 k $\Omega$
Input limit values	Voltage at state 1	> 15 Vdc (15...28.8 Vdc)
	Voltage at state 0	< 5 Vdc (0...5 Vdc)
	Current at state 1	> 2.5 mA
	Current at state 0	<1 mA
Turn on time		4 ms
Turn off time		4 ms
Isolation	Between input and internal logic	500 Vac
	Between input groups	500 Vac
Connection type		HE10 (MIL 20) connectors
Connector insertion/removal durability		Over 100 times
Current draw on 5 Vdc internal bus		65 mA (all inputs on)
		5 mA (all inputs off)
Current draw on 24 Vdc internal bus		0 mA (all inputs on)
		0 mA (all inputs off)

### I/O Re-rating

When using TM3DI32K:

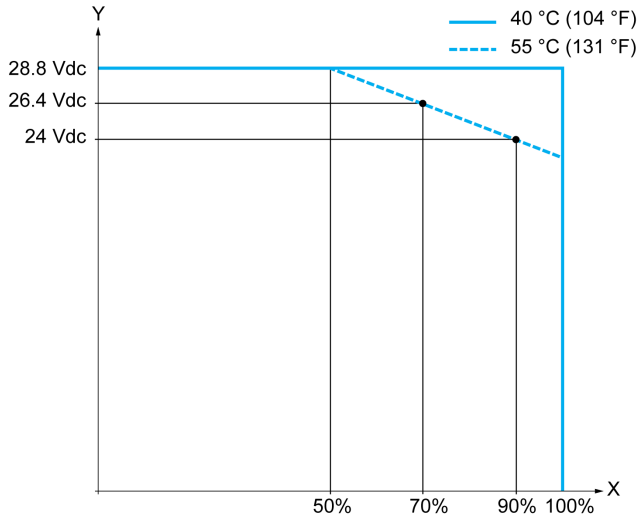

**X** Input simultaneous ON ratio  
**Y** Input voltage

## TM3DI32K Wiring Diagram

### Introduction

This expansion module has a built-in HE10 (MIL 20) connector for the connection of inputs and power supply.

### Wiring Rules

See Wiring Best Practices ([see page 47](#)).

### Wiring Diagram with Free-Wire Cables

The following figure illustrates the connection between the inputs, the sensors, and their commons:

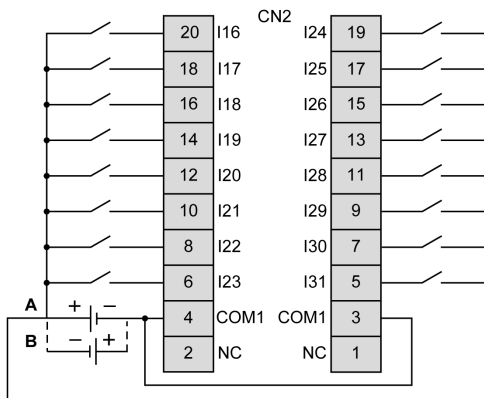
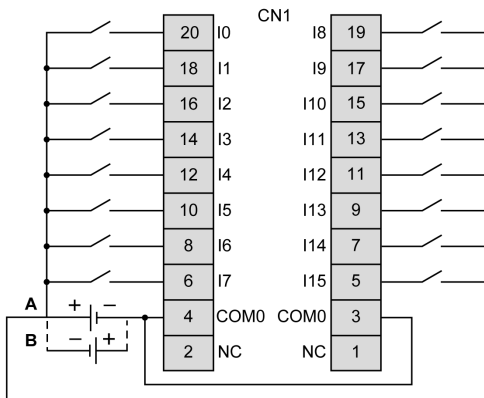

The COM0 and COM1 terminals are **not** connected internally

- A Sink wiring (positive logic)
- B Source wiring (negative logic)

For information about 24 Vdc power supply, refer to DC Power Supply Characteristics (see page 53).

For more information on the cable color for TWDFCW30K/TWDFCW50K, refer to TWDFCW\*\*K Cable Description.

### Wiring Diagram with Telefast ABE7E16EPN20 Pre-Wiring Sub-bases

The following figure shows the ABE7E16EPN20 sub-base:

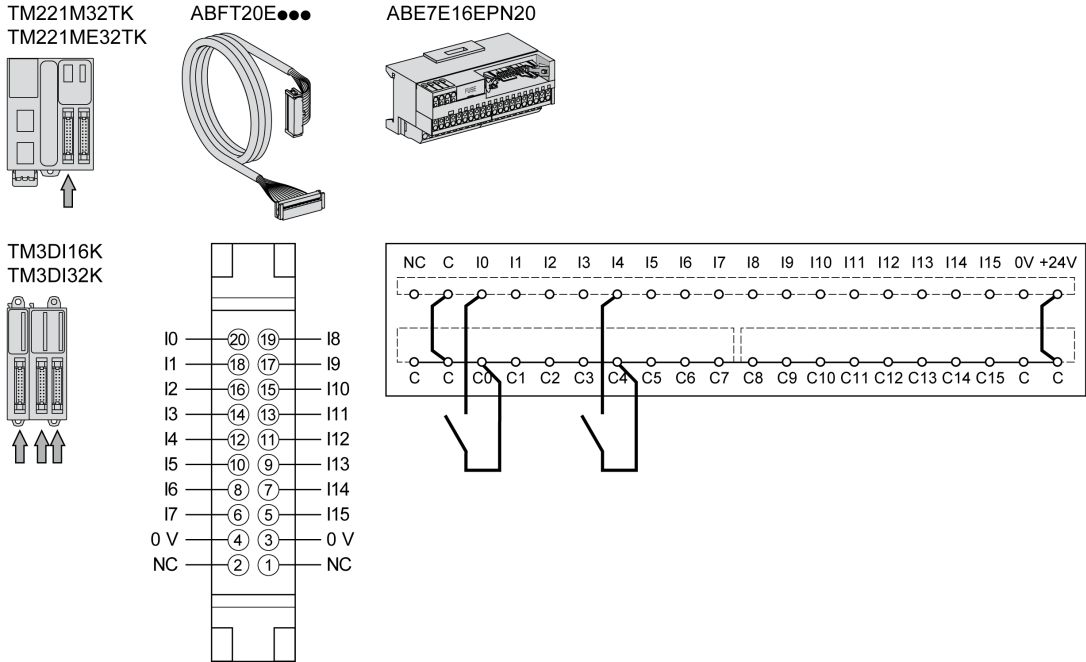

For more information on the Telefast cable, refer to Telefast Pre-wiring Sub-bases (see page 24).

---

## Part III

### TM3 Digital Output Modules

---

#### What Is in This Part?

This part contains the following chapters:

Chapter	Chapter Name	Page
8	TM3DQ8R / TM3DQ8RG Module 8 Relay Outputs 2A 24 Vdc/240 Vac	95
9	TM3DQ8T / TM3DQ8TG Module 8 Regular Transistor Source Outputs 0.5A 24 Vdc	103
10	TM3DQ8U / TM3DQ8UG Module 8 Regular Transistor Sink Outputs 0.5A 24 Vdc	109
11	TM3DQ16R / TM3DQ16RG Module 16 Relay Outputs 2A 24 Vdc/240 Vac	115
12	TM3DQ16T / TM3DQ16TG Module 16 Regular Transistor Source Outputs 0.5A 24 Vdc	123
13	TM3DQ16TK Module 16 Regular Transistor Source Outputs 0.1A 24 Vdc	129
14	TM3DQ16U / TM3DQ16UG Module 16 Regular Transistor Sink Outputs 0.3A 24 Vdc	139
15	TM3DQ16UK Module 16 Regular Transistor Sink Outputs 0.1A 24 Vdc	145
16	TM3DQ32TK Module 32 Regular Transistor Outputs 0.1A 24 Vdc	151
17	TM3DQ32UK Module 32 Regular Transistor Outputs 0.1A 24 Vdc	161



---

# Chapter 8

## TM3DQ8R / TM3DQ8RG Module 8 Relay Outputs 2A 24 Vdc/240 Vac

---

### Overview

This chapter describes the TM3DQ8R / TM3DQ8RG expansion modules, its characteristics and its connection to the different actuators.

### What Is in This Chapter?

This chapter contains the following topics:

Topic	Page
TM3DQ8R / TM3DQ8RG Presentation	96
TM3DQ8R / TM3DQ8RG Characteristics	98
TM3DQ8R / TM3DQ8RG Wiring Diagram	102

## TM3DQ8R / TM3DQ8RG Presentation

### Overview

TM3DQ8R (screw) and TM3DQ8RG (spring) digital expansion module:

- 8 channels
- 2 A relay outputs
- 1 common line
- Removable screw or spring terminal block

### Main Characteristics

Characteristic		Value
Number of output channels		8 outputs
Contact type		NO (Normally Open)
Output type		Relay
Rated output voltage		24 Vdc / 240 Vac
Rated output current		2 A
Connection type	TM3DQ8R	Removable screw terminal block
	TM3DQ8RG	Removable spring terminal block
Cable type and length	Type	Unshielded
	Length	Max. 30 m (98 ft)
Weight		110 g (3.90 oz)



## Status LEDs

The following figure shows the status LEDs:



This table describes the status LED:

LED	Color	Status	Description
0...7	Green	On	The output channel is activated.
		Off	The output channel is deactivated.

## TM3DQ8R / TM3DQ8RG Characteristics

### Introduction

This section provides a description of the power limitation and the output characteristics of the TM3DQ8R / TM3DQ8RG expansion modules.

See also Environmental Characteristics ([see page 29](#)).

### DANGER

#### **FIRE HAZARD**

- Use only the recommended wire sizes for the current capacity of the I/O channels and power supplies.
- For relay output (2 A) wiring, use conductors of at least 0.5 mm<sup>2</sup> (AWG 20) with a temperature rating of at least 80 °C (176 °F).
- For common conductors of relay output wiring (7 A), or relay output wiring greater than 2 A, use conductors of at least 1.0 mm<sup>2</sup> (AWG 16) with a temperature rating of at least 80 °C (176 °F).

**Failure to follow these instructions will result in death or serious injury.**

### WARNING

#### **UNINTENDED EQUIPMENT OPERATION**

Do not exceed any of the rated values specified in the environmental and electrical characteristics tables.

**Failure to follow these instructions can result in death, serious injury, or equipment damage.**

## Dimensions

The following diagrams show the external dimensions for the TM3DQ8R / TM3DQ8RG expansion modules:

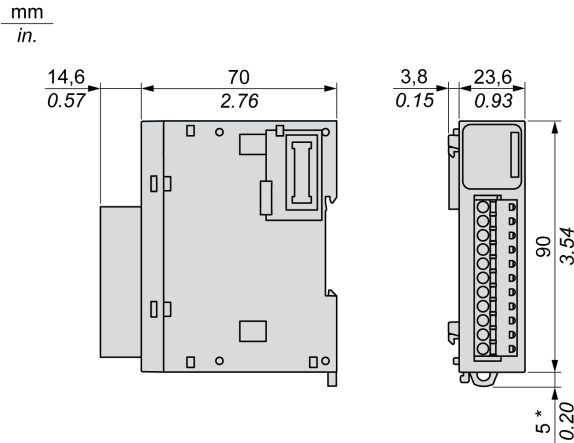

**NOTE:** \* 8.5 mm (0.33 in) when the clamp is pulled out.

## Output Characteristics

The table below describes the outputs characteristics of the TM3DQ8R / TM3DQ8RG:

Characteristic		Value
Number of output channels		8
Number of channel groups		2 common lines, one for each group of 4 channels
Output type		Relay
Contact type		NO (Normally Open)
Rated output voltage		24 Vdc, 240 Vac
Maximum voltage		30 Vdc, 264 Vac
Minimum switching load		5 Vdc at 10 mA
Rated output current		2 A
Maximum output current		2 A per output 7 A per common
Maximum output frequency with maximum load		20 operations per minute
Turn on time		Max. 10 ms
De-rating	-10...55 °C (14...131 °F)	No de-rating
Turn off time		Max. 10 ms

Characteristic		Value
Contact resistance		30 mΩ max
Mechanical life		20 million operations
Electrical life	Under resistive load	See Power limitation ( <a href="#">see page 101</a> )
	Under inductive load	
Protection against short circuit		No
Isolation	Between output and internal logic	500 Vac
	Between channel groups	1500 Vac
Connection type	TM3DQ8R	Removable screw terminal block
	TM3DQ8RG	Removable spring terminal block
Connector insertion/removal durability		Over 100 times
Current draw on 5 Vdc internal bus		30 mA (all outputs on) 5 mA (all outputs off)
Current draw on 24 Vdc internal bus		40 mA (all outputs on) 0 mA (all outputs off)
<b>NOTE:</b> Refer to Protecting Outputs from Inductive Load Damage ( <a href="#">see page 51</a> ) for additional information concerning output protection.		

## Power Limitation

This table describes the power limitations of the TM3DQ8R / TM3DQ8RG expansion module depending on the voltage, the type of load, and the number of operations required.

These expansion modules do not support capacitive loads.

### WARNING

#### RELAY OUTPUTS WELDED CLOSED

- Always protect relay outputs from inductive alternating current load damage using an appropriate external protective circuit or device.
- Do not connect relay outputs to capacitive loads.

**Failure to follow these instructions can result in death, serious injury, or equipment damage.**

Power Limitations				
Voltage	24 Vdc	120 Vac	240 Vac	Number of operations
Power of resistive loads AC-12	–	240 VA 80 VA	480 VA 160 VA	100,000 300,000
Power of inductive loads AC-15 (cos $\varphi$ = 0.35)	–	60 VA 18 VA	120 VA 36 VA	100,000 300,000
Power of inductive loads AC-14 (cos $\varphi$ = 0.7)	–	120 VA 36 VA	240 VA 72 VA	100,000 300,000
Power of resistive loads DC-12	48 W 16 W	–	–	100,000 300,000
Power of inductive loads DC-13 L/R = 7 ms	24 W 7.2 W	–	–	100,000 300,000

## TM3DQ8R / TM3DQ8RG Wiring Diagram

### Introduction

These expansion modules have a built-in removable screw or spring terminal block for the connection of outputs and power supply.

### Wiring Rules

See Wiring Best Practices ([see page 47](#)).

### Wiring Diagram

The following figure illustrates the connections between the outputs, the actuators, and their commons:

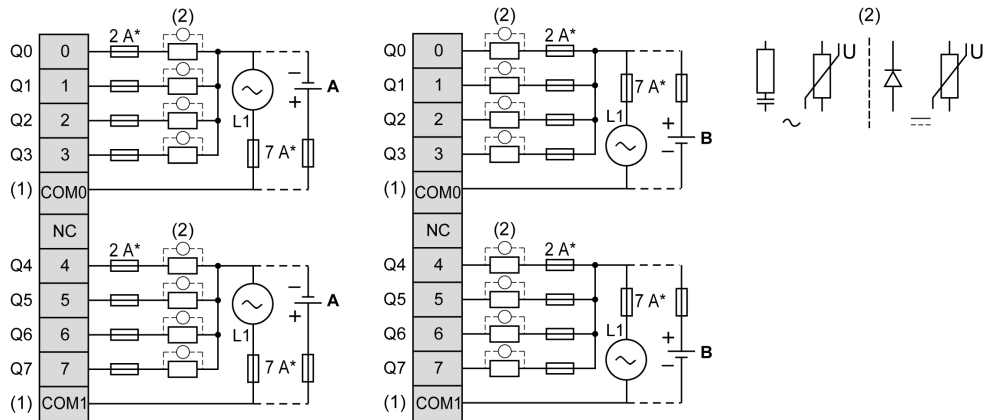

\* Type T fuse

(1) The COM0 and COM1 terminals are not connected internally

(2) To improve the life time of the contacts, and to protect from potential inductive load damage, connect a free wheeling diode in parallel to each inductive DC load or an RC snubber in parallel of each inductive AC load.

A Source wiring (positive logic)

B Sink wiring (negative logic)

For information about 24 Vdc power supply, refer to DC Power Supply Characteristics ([see page 53](#)).

## ⚠ WARNING

### UNINTENDED EQUIPMENT OPERATION

Do not connect wires to unused terminals and/or terminals indicated as “No Connection (N.C.)”.

**Failure to follow these instructions can result in death, serious injury, or equipment damage.**

---

# Chapter 9

## TM3DQ8T / TM3DQ8TG Module 8 Regular Transistor Source Outputs 0.5A 24 Vdc

---

### Overview

This chapter describes the TM3DQ8T / TM3DQ8TG module, its characteristics, and its connection to the different actuators.

### What Is in This Chapter?

This chapter contains the following topics:

Topic	Page
TM3DQ8T / TM3DQ8TG Presentation	104
TM3DQ8T / TM3DQ8TG Characteristics	105
TM3DQ8T / TM3DQ8TG Wiring Diagram	107

## TM3DQ8T / TM3DQ8TG Presentation

### Overview

TM3DQ8T (screw) and TM3DQ8TG (spring) digital expansion module:

- 8 channels
- 0.5 A source outputs
- 1 common line
- removable screw or spring terminal block

### Main Characteristics

Characteristic		Value
Number of output channels		8
Logic type		Source
Rated output voltage		24 Vdc
Rated output current		0.5 A
Connection type	TM3DQ8T	Removable screw terminal block
	TM3DQ8TG	Removable spring terminal block
Cable type and length	Type	Unshielded
	Length	Max. 30 m (98 ft)
Weight		76 g (2.7 oz)

### Status LEDs

The following figure shows the status LEDs:



This table describes the status LEDs:

LED	Color	Status	Description
0...7	Green	On	The output channel is activated
		Off	The output channel is deactivated



## TM3DQ8T / TM3DQ8TG Characteristics

### Introduction

This section provides a description of the output characteristics of the TM3DQ8T / TM3DQ8TG expansion modules.

See also Environmental Characteristics ([see page 29](#)).

## ⚠ WARNING

### UNINTENDED EQUIPMENT OPERATION

Do not exceed any of the rated values specified in the environmental and electrical characteristics tables.

**Failure to follow these instructions can result in death, serious injury, or equipment damage.**

### Dimensions

The following diagrams show the external dimensions for the TM3DQ8T / TM3DQ8TG expansion modules:

mm  
in.

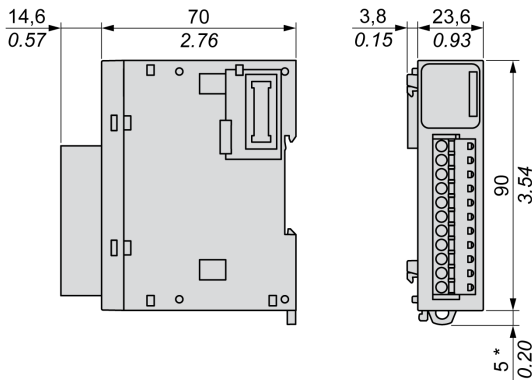

**NOTE:** \* 8.5 mm (0.33 in) when the clamp is pulled out.

## Output Characteristics

The table below describes the outputs characteristics of the TM3DQ8T / TM3DQ8TG:

Characteristic		Value
Number of output channels		8
Number of channel groups		1 common line for 8 channels
Output type		Transistor
Logic type		Source
Rated output voltage		24 Vdc
Output voltage range		19.2...28.8 Vdc
Rated output current		0.5 A max. per channel
Total output current per group		4 A
Voltage drop		0.4 Vdc max.
Leakage current when switched off		0.1 mA max.
Maximum power of filament lamp		12 W
Inductive load		L/R = 10 ms
De-rating	- 10...55 °C (14...131 °F)	No de-rating
Turn on time		450 µs
Turn off time		450 µs
Protection against short circuit		Yes
Short circuit output peak current		1 A typically
Automatic rearming after short circuit or overload		Yes, time depending on the expansion module temperature
Protection against reverse polarity		Yes
Clamping voltage		Typically 50 Vdc
Switching frequency	Under resistive load	100 Hz max.
Isolation	Between output and internal logic	500 Vac
	Between channel group	N/A
Connection type	TM3DQ8T	Removable screw terminal block
	TM3DQ8TG	Removable spring terminal block
Connector insertion/removal durability		Over 100 times
Current draw on 5 Vdc internal bus		10 mA (all outputs on) 5 mA (all outputs off)
Current draw on 24 Vdc internal bus		20 mA (all outputs on) 0 mA (all outputs off)
<b>NOTE:</b> Refer to Protecting Outputs from Inductive Load Damage ( <a href="#">see page 51</a> ) for additional information concerning output protection.		

## TM3DQ8T / TM3DQ8TG Wiring Diagram

### Introduction

These expansion modules have a built-in removable screw or spring terminal block for the connection of outputs and power supply.

### Wiring Rules

See Wiring Best Practices ([see page 47](#)).

### Wiring Diagram

The following figure illustrates the connections between the outputs, the actuators, and their commons:

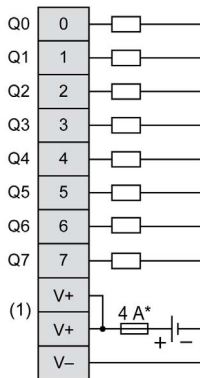

\* Type T fuse

(1) The V+ terminals are connected internally.

For information about 24 Vdc power supply, refer to DC Power Supply Characteristics ([see page 53](#)).



---

# Chapter 10

## TM3DQ8U / TM3DQ8UG Module 8 Regular Transistor Sink Outputs 0.5A 24 Vdc

---

### Overview

This chapter describes the TM3DQ8U / TM3DQ8UG module, its characteristics, and its connection to the different actuators.

### What Is in This Chapter?

This chapter contains the following topics:

Topic	Page
TM3DQ8U / TM3DQ8UG Presentation	110
TM3DQ8U / TM3DQ8UG Characteristics	111
TM3DQ8U / TM3DQ8UG Wiring Diagram	113

## TM3DQ8U / TM3DQ8UG Presentation

### Overview

TM3DQ8U (screw) and TM3DQ8UG (spring) digital expansion module:

- 8-channels
- 0.5 A sink outputs
- 1 common line
- removable screw or spring terminal block

### Main Characteristics

Characteristic		Value
Number of output channels		8
Logic type		Sink
Rated output voltage		24 Vdc
Rated output current		0.5 A
Connection type	TM3DQ8U	Removable screw terminal block
	TM3DQ8UG	Removable spring terminal block
Cable type and length	Type	Unshielded
	Length	Max. 30 m (98 ft)
Weight		76 g (2.7 oz)

### Status LEDs

The following figure shows the status LEDs:



This table describes the status LEDs:

LED	Color	Status	Description
0...7	Green	On	The output channel is activated.
		Off	The output channel is deactivated.

## TM3DQ8U / TM3DQ8UG Characteristics

### Introduction

This section provides a description of the electrical and output characteristics of the TM3DQ8U / TM3DQ8UG expansion modules.

See also Environmental Characteristics ([see page 29](#)).

### **⚠ WARNING**

#### **UNINTENDED EQUIPMENT OPERATION**

Do not exceed any of the rated values specified in the environmental and electrical characteristics tables.

**Failure to follow these instructions can result in death, serious injury, or equipment damage.**

### Dimensions

The following diagrams show the external dimensions for the TM3DQ8U / TM3DQ8UG expansion modules:

mm  
in.

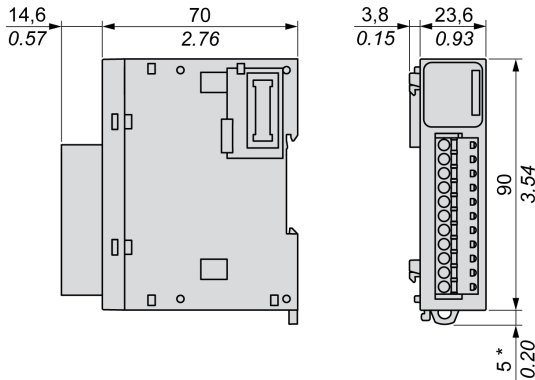

**NOTE:** \* 8.5 mm (0.33 in) when the clamp is pulled out.

## Output Characteristics

The table below describes the outputs characteristics of the TM3DQ8U / TM3DQ8UG:

Characteristic		Value
Number of output channels		8
Number of channel groups		1 common line for 8 channels
Output type		Transistor
Logic type		Sink
Rated output voltage		24 Vdc
Output voltage range		19.2...28.8 Vdc
Rated output current		0.5 A max. per channel
Total output current per group		4 A
Voltage drop		0.4 V max.
Leakage current when switched off		0.1 mA max.
Maximum power of filament lamp		12 W
Inductive load		L/R = 10 ms
De-rating	- 10...55 °C(14...131 °F)	No de-rating
Turn on time		450 µs
Turn off time		450 µs
Protection against short circuit		No Fast external fuse required
Short circuit output peak current		N/A
Automatic rearming after short circuit or overload		N/A
Protection against reverse polarity		No
Clamping voltage		Typically 50 Vdc
Switching frequency	Under resistive load	100 Hz max.
Isolation	Between output and internal logic	500 Vac
	Between channel group	N/A
Connection type	TM3DQ8U	Removable screw terminal block
	TM3DQ8UG	Removable spring terminal block
Connector insertion/removal durability		Over 100 times
Current draw on 5 Vdc internal bus		10 mA (all outputs on) 5 mA (all outputs off)
Current draw on 24 Vdc internal bus		20 mA (all outputs on) 0 mA (all outputs off)
<b>NOTE:</b> Refer to Protecting Outputs from Inductive Load Damage ( <a href="#">see page 51</a> ) for additional information concerning output protection.		



## TM3DQ8U / TM3DQ8UG Wiring Diagram

### Introduction

These expansion modules have a built-in removable screw or spring terminal block for the connection of outputs and power supply.

### Wiring Rules

See Wiring Best Practices ([see page 47](#)).

### Wiring Diagram

The following figure illustrates the connections between the outputs, the actuators, and their commons:

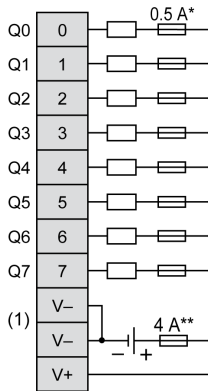

\* Type T fuse

\*\* Type F fuse

(1) The V- terminals are connected internally.

For information about 24 Vdc power supply, refer to DC Power Supply Characteristics ([see page 53](#)).



---

# Chapter 11

## TM3DQ16R / TM3DQ16RG Module 16 Relay Outputs 2A 24 Vdc/240 Vac

---

### Overview

This chapter describes the TM3DQ16R / TM3DQ16RG expansion modules, its characteristics, and its connection to the different actuators.

### What Is in This Chapter?

This chapter contains the following topics:

Topic	Page
TM3DQ16R / TM3DQ16RG Presentation	116
TM3DQ16R / TM3DQ16RG Characteristics	118
TM3DQ16R / TM3DQ16RG Wiring Diagram	121

## TM3DQ16R / TM3DQ16RG Presentation

### Overview

TM3DQ16R (screw) and TM3DQ16RG (spring) digital expansion module:

- 16 channels
- 2 A relay outputs
- 2 common lines
- removable screw or spring terminal blocks

### Main Characteristics

Characteristic		Value
Number of output channels		16 outputs
Contact type		NO (Normally Open)
Output type		Relay
Rated output voltage		24 Vdc, 240 Vac
Rated output current		2 A
Connection type	TM3DQ16R	Removable screw terminal blocks
	TM3DQ16RG	Removable spring terminal blocks
Cable type and length	Type	Unshielded
	Length	Max. 30 m (98 ft)
Weight		145 g (5.11 oz)

## Status LEDs

The following figure shows the status LEDs:

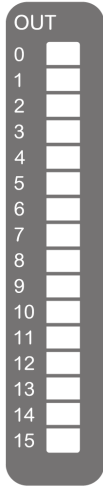

This table describes the status LEDs:

LED	Color	Status	Description
0...15	Green	On	The output channel is activated
		Off	The output channel is deactivated

## TM3DQ16R / TM3DQ16RG Characteristics

### Introduction

This section provides a description of the electrical and the output characteristics of the TM3DQ16R / TM3DQ16RG expansion modules.

See also Environmental Characteristics ([see page 29](#)).

### **⚠ WARNING**

#### **UNINTENDED EQUIPMENT OPERATION**

Do not exceed any of the rated values specified in the environmental and electrical characteristics tables.

**Failure to follow these instructions can result in death, serious injury, or equipment damage.**

### Dimensions

The following diagrams show the external dimensions for the TM3DQ16R / TM3DQ16RG expansion modules:

$\frac{\text{mm}}{\text{in.}}$

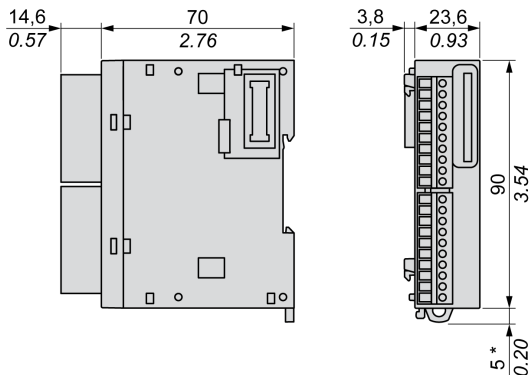

**NOTE:** \* 8.5 mm (0.33 in) when the clamp is pulled out.

## Output Characteristics

The table below describes the outputs characteristics of the TM3DQ16R / TM3DQ16RG:

Characteristic		Value
Number of output channels		8
Number of channel groups		2 common lines, one on 2 terminals for each group of 8 channels
Output type		Relay
Contact type		NO (Normally Open)
Rated output voltage		24 Vdc, 240 Vac
Maximum voltage		30 Vdc, 264 Vac
Minimum switching load		5 Vdc at 10 mA
Rated output current		2 A
Maximum output current		2 A per output
		8 A per common
Maximum output frequency	with maximum load	20 operations per minute
De-rating	-10...55 °C (14...131 °F)	No de-rating
Turn on time		Typically 10 ms
Turn off time		Typically 10 ms
Contact resistance		30 mΩ max
Mechanical life		20 million operations
Electrical life	Under resistive load	See Power limitation ( <a href="#">see page 120</a> )
	Under inductive load	
Protection against short circuit		No
Isolation	Between output and internal logic	500 Vac
	Between channel groups	1500 Vac
Connection type	TM3DQ16R	Removable screw terminal block
	TM3DQ16RG	Removable spring terminal block
Connector insertion/removal durability		Over 100 times
Current draw on 5 Vdc internal bus		45 mA (all outputs on) 5 mA (all outputs off)
Current draw on 24 Vdc internal bus		75 mA (all outputs on) 0 mA (all outputs off)
<b>NOTE:</b> Refer to Protecting Outputs from Inductive Load Damage ( <a href="#">see page 51</a> ) for additional information concerning output protection.		

### Power Limitation

This table describes the power limitation of the TM3DQ16R / TM3DQ16RG expansion modules depending on the voltage, the type of load, and the number of operations required.

These expansion modules do not support capacitive loads.

## **WARNING**

### **RELAY OUTPUTS WELDED CLOSED**

- Always protect relay outputs from inductive alternating current load damage using an appropriate external protective circuit or device.
- Do not connect relay outputs to capacitive loads.

**Failure to follow these instructions can result in death, serious injury, or equipment damage.**

<b>Power Limitations</b>				
<b>Voltage</b>	<b>24 Vdc</b>	<b>120 Vac</b>	<b>240 Vac</b>	<b>Number of operations</b>
Power of resistive loads AC-12	–	240 VA 80 VA	480 VA 160 VA	100,000 300,000
Power of inductive loads AC-15 (cos φ = 0.35)	–	60 VA 18 VA	120 VA 36 VA	100,000 300,000
Power of inductive loads AC-14 (cos φ = 0.7)	–	120 VA 36 VA	240 VA 72 VA	100,000 300,000
Power of resistive loads DC-12	48 W 16 W	–	–	100,000 300,000
Power of inductive loads DC-13 L/R = 7 ms	24 W 7.2 W	–	–	100,000 300,000



## TM3DQ16R / TM3DQ16RG Wiring Diagram

### Introduction

These expansion modules have a built-in removable screw or spring terminal block for the connection of the outputs and power supply.

### Wiring Rules

See Wiring Best Practices ([see page 47](#)).

### Wiring Diagram

The following figure illustrates the connections between the outputs, the actuators, and their commons:

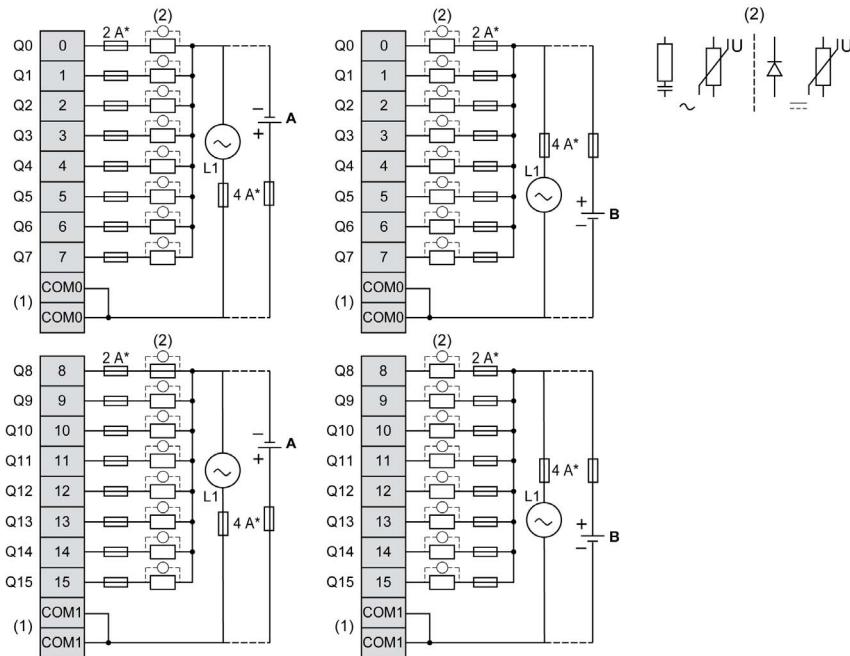

\* Type T fuse

(1) The COM0 and COM1 terminals are **not** connected internally.

(2) To improve the life time of the contacts, and to protect from potential inductive load damage, connect a free wheeling diode in parallel to each inductive DC load or an RC snubber in parallel of each inductive AC load.

A Source wiring (positive logic)

B Sink wiring (negative logic)

For information about 24 Vdc power supply, refer to DC Power Supply Characteristics ([see page 53](#)).



---

# Chapter 12

## TM3DQ16T / TM3DQ16TG Module 16 Regular Transistor Source Outputs 0.5A 24 Vdc

---

### Overview

This chapter describes the TM3DQ16T / TM3DQ16TG expansion module, its characteristics, and its connection to the different actuators.

### What Is in This Chapter?

This chapter contains the following topics:

Topic	Page
TM3DQ16T / TM3DQ16TG Presentation	124
TM3DQ16T / TM3DQ16TG Characteristics	126
TM3DQ16T / TM3DQ16TG Wiring Diagram	128

## TM3DQ16T / TM3DQ16TG Presentation

### Overview

TM3DQ16T (screw), TM3DQ16TG (spring) digital expansion module:

- 16 channels
- 0.5 A source outputs
- 1 common line
- Removable screw or spring terminal block

### Main Characteristics

Characteristic		Value
Number of output channels		16
Logic type		Source
Rated output voltage		24 Vdc
Rated output current		0.5 A
Connection type	TM3DQ16T	Removable screw terminal blocks
	TM3DQ16TG	Removable spring terminal blocks
Cable type and length	Type	Unshielded
	length	Max. 30 m (98 ft)
Weight		110 g (3.90 oz)

## Status LEDs

The following figures show the status LEDs:

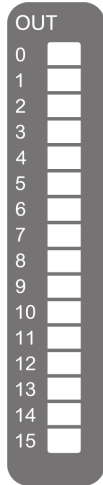

This table describes the status LEDs:

LED	Color	Status	Description
0...15	Green	On	The output channel is activated
		Off	The output channel is deactivated

## TM3DQ16T / TM3DQ16TG Characteristics

### Introduction

This section provides a description of the electrical and the output characteristics of the TM3DQ16T / TM3DQ16TG expansion modules.

See also Environmental Characteristics ([see page 29](#)).

## ⚠ WARNING

### UNINTENDED EQUIPMENT OPERATION

Do not exceed any of the rated values specified in the environmental and electrical characteristics tables.

**Failure to follow these instructions can result in death, serious injury, or equipment damage.**

### Dimensions

The following diagrams show the external dimensions for the TM3DQ16T / TM3DQ16TG expansion modules:

mm  
in.

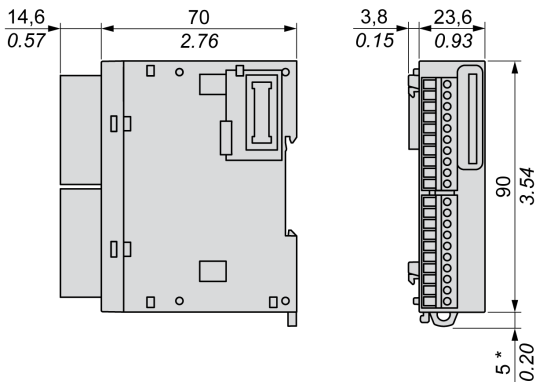

\* 8.5 mm (0.33 in) when the clamp is pulled out.

## Output Characteristics

The table below describes the outputs characteristics of the TM3DQ16T and TM3DQ16TG

Characteristic		Value
Number of output channels		16
Number of channel groups		1 common line on 2 terminals for 16 channels
Output type		Transistor
Logic type		Source
Rated output voltage		24 Vdc
Output voltage range		19.2...28.8 Vdc
Rated output current		0.5 A
Total output current per group		4 A
Voltage drop		0.4 Vdc max.
Leakage current when switched off		0.1 mA max.
Maximum power of filament lamp		3 W
Inductive load		L/R = 10 ms
De-rating	- 10...55 °C(14...131 °F)	No de-rating
Turn on time		450 µs
Turn off time		450 µs
Protection against short circuit		Yes
Short circuit output peak current		1 A typically
Automatic rearming after short circuit or overload		Yes, time depending on component temperature
Protection against reverse polarity		Yes
Clamping voltage		Typically 50 Vdc
Switching frequency	Under resistive load	100 Hz max.
Isolation	Between channel group	500 Vac
	Between channel group	N/A
Connection type	TM3DQ16T	Removable screw terminal blocks
	TM3DQ16TG	Removable spring terminal blocks
Connector insertion/removal durability		Over 100 times
Current draw on 5 Vdc internal bus		15 mA (all outputs on) 5 mA (all outputs off)
Current draw on 24 Vdc internal bus		20 mA (all outputs on) 0 mA (all outputs off)
<b>NOTE:</b> Refer to Protecting Outputs from Inductive Load Damage ( <a href="#">see page 51</a> ) for additional information concerning output protection.		

## TM3DQ16T / TM3DQ16TG Wiring Diagram

### Introduction

These expansion modules have a built-in removable screw or spring terminal block for the connection of outputs and power supply.

### Wiring Rules

See Wiring Best Practices (*see page 47*).

### Wiring Diagram

The following figure illustrates the connections between the outputs, the actuators, and their commons:

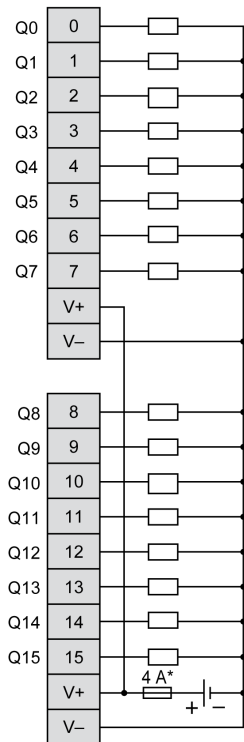

\* Type T fuse

For information about 24 Vdc power supply, refer to DC Power Supply Characteristics (*see page 53*).



---

# Chapter 13

## TM3DQ16TK Module 16 Regular Transistor Source Outputs 0.1A 24 Vdc

---

### Overview

This chapter describes the TM3DQ16TK expansion module, its characteristics, and its connection to the different actuators.

### What Is in This Chapter?

This chapter contains the following topics:

Topic	Page
TM3DQ16TK Presentation	130
TM3DQ16TK Characteristics	132
TM3DQ16TK Wiring Diagram	134

## TM3DQ16TK Presentation

### Overview

TM3DQ16TK (HE10) digital expansion module:

- 16 channels
- 0.1 A source outputs
- 1 common line
- HE10 (MIL 20) connector

### Main Characteristics

Characteristic		Value
Number of output channels		16
Logic type		Source
Rated output voltage		24 Vdc
Rated output current		0.1 A
Connection type	TM3DQ16TK	HE10 (MIL 20) connector
Cable type and length	Type	Unshielded
	length	Max. 5 m (16 ft)
Weight		72 g (2.54 oz)

### Status LEDs

The following figures show the status LEDs:

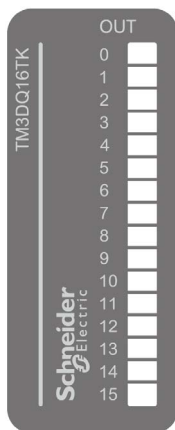

This table describes the status LEDs:

LED	Color	Status	Description
0...15	Green	On	The output channel is activated
		Off	The output channel is deactivated

## TM3DQ16TK Characteristics

### Introduction

This section provides a description of the electrical and the output characteristics of the TM3DQ16TK expansion module.

See also Environmental Characteristics ([see page 29](#)).

## ⚠ WARNING

### UNINTENDED EQUIPMENT OPERATION

Do not exceed any of the rated values specified in the environmental and electrical characteristics tables.

**Failure to follow these instructions can result in death, serious injury, or equipment damage.**

### Dimensions

The following diagrams show the external dimensions for the TM3DQ16TK expansion module:

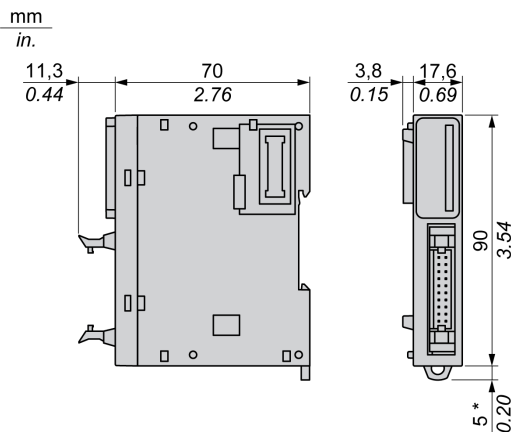

\* 8.5 mm (0.33 in) when the clamp is pulled out.

## Output Characteristics

The table below describes the outputs characteristics of the TM3DQ16TK:

Characteristic		Value
Number of output channels		16
Number of channel groups		1 common line on 2 pins for 16 channels
Output type		Transistor
Logic type		Source
Rated output voltage		24 Vdc
Output voltage range		19.2...28.8 Vdc
Rated output current		0.1 A max. per channel
Total output current per group		2 A
Voltage drop		0.4 Vdc max.
Leakage current when switched off		0.1 mA max.
Maximum power of filament lamp		9.6 W
Inductive load		L/R = 10 ms
De-rating	- 10...55 °C(14...131 °F)	No de-rating
Turn on time		450 µs
Turn off time		450 µs
Protection against short circuit		Yes
Short circuit output peak current		1 A typically
Automatic rearming after short circuit or overload		Yes, time depending on component temperature
Protection against reverse polarity		Yes
Clamping voltage		Typically 50 Vdc
Switching frequency	Under resistive load	100 Hz max.
Isolation	Between output and internal logic	500 Vac
	Between channel group	N/A
Connection type		HE10 (MIL 20) connector
Connector insertion/removal durability		Over 100 times
Current draw on 5 Vdc internal bus		15 mA (all outputs on) 5 mA (all outputs off)
Current draw on 24 Vdc internal bus		20 mA (all outputs on) 0 mA (all outputs off)
<b>NOTE:</b> Refer to Protecting Outputs from Inductive Load Damage ( <a href="#">see page 51</a> ) for additional information concerning output protection.		

## TM3DQ16TK Wiring Diagram

### Introduction

This expansion module has a built-in HE10 (MIL 20) connector for the connection of outputs and power supply.

### Wiring Rules

See Wiring Best Practices ([see page 47](#)).

### Wiring Diagram with Free-Wire Cables

The following figure illustrates the connections between the outputs, the actuators, and their commons:

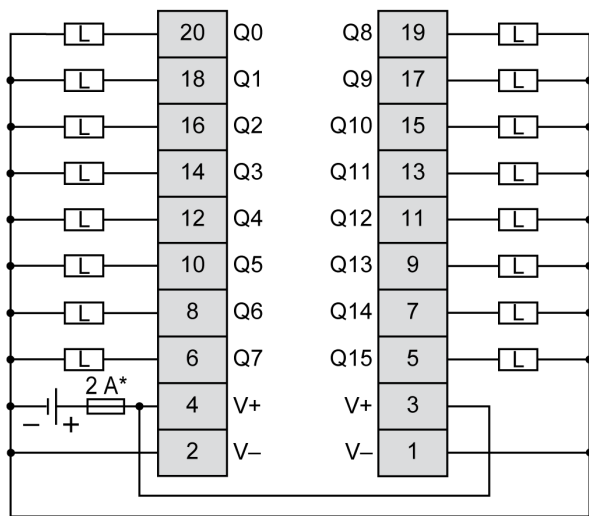

\* Type T fuse

For information about 24 Vdc power supply, refer to DC Power Supply Characteristics ([see page 53](#)).

For more information on the cable color for TWDFCW30K/TWDFCW50K, refer to TWDFCW••K Cable Description.

### Wiring Diagrams with Telefast ABE7E16SPN2-/ABE7E16SRM20 Pre-Wiring Sub-bases

The following figure shows the ABE7E16SPN20 sub-base:

TM221M32TK  
TM221ME32TK

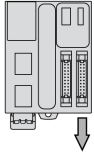

ABFT20E●●●



ABE7E16SPN20

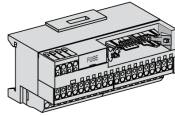

TM3DQ16TK  
TM3DQ32TK

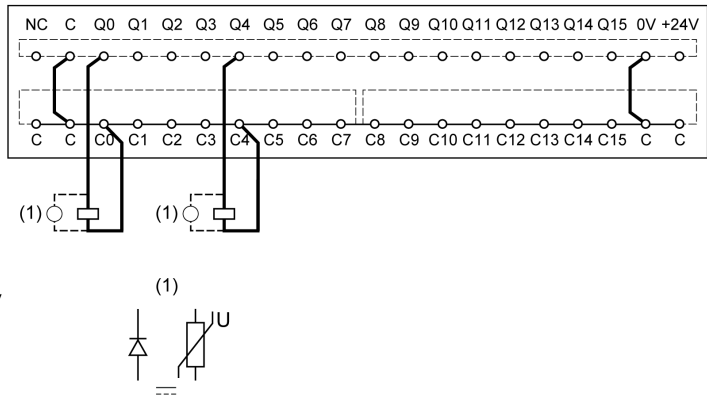
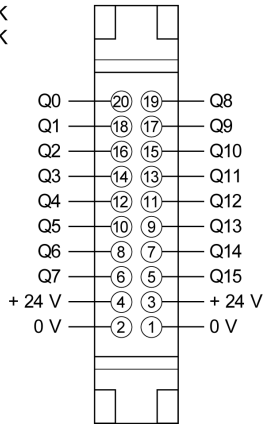
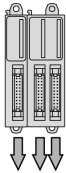

- (1) To improve the life time of the contacts, and to protect from potential inductive load damage, it is recommended to connect a free wheeling diode in parallel to each inductive DC load or an RC snubber in parallel of each inductive AC load

The following figure shows the ABE7E16SPN22 sub-base:

TM221M32TK  
TM221ME32TK

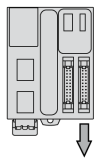

ABFT20E●●●



ABE7E16SPN22

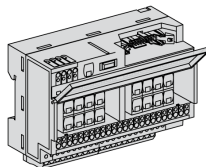

TM3DQ16TK  
TM3DQ32TK

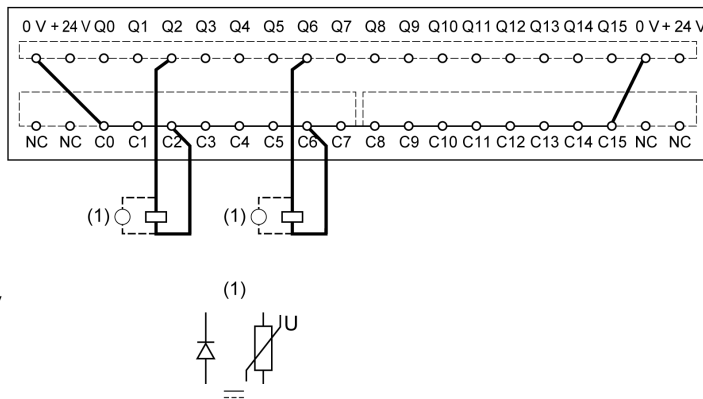
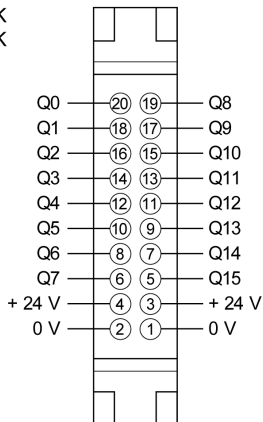
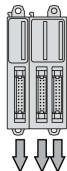

- (1) To improve the life time of the contacts, and to protect from potential inductive load damage, it is recommended to connect a free wheeling diode in parallel to each inductive DC load or an RC snubber in parallel of each inductive AC load



The following figure shows the ABE7E16SRM20 sub-base:

TM221M32TK  
TM221ME32TK

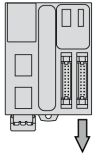

ABFT20E●●●



ABE7E16SRM20

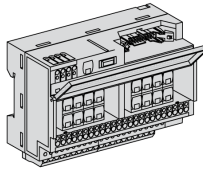

TM3DQ16TK  
TM3DQ32TK

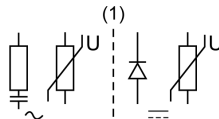
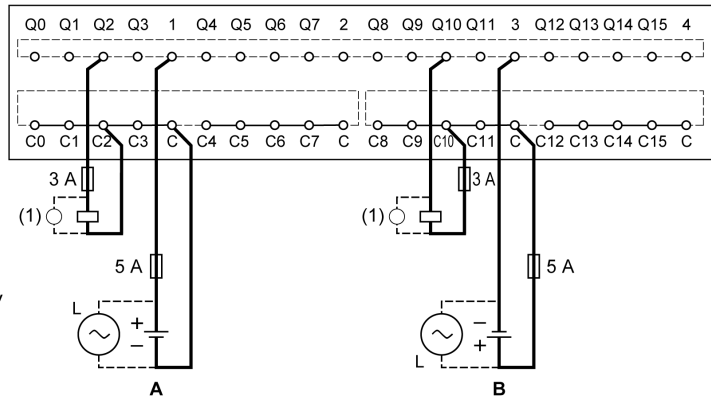
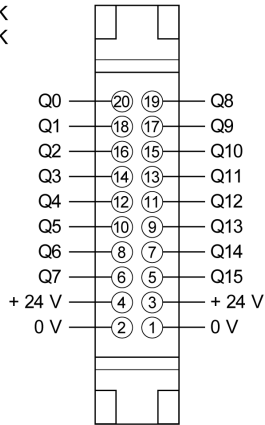
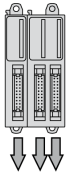

(1) To improve the life time of the contacts, and to protect from potential inductive load damage, it is recommended to connect a free wheeling diode in parallel to each inductive DC load or an RC snubber in parallel of each inductive AC load

**A** Source wiring (positive logic)

**B** Sink wiring (negative logic)

For more information on the Telefast cable, refer to Telefast Pre-wiring Sub-bases ([see page 24](#)).



---

# Chapter 14

## TM3DQ16U / TM3DQ16UG Module 16 Regular Transistor Sink Outputs 0.3A 24 Vdc

---

### Overview

This chapter describes the TM3DQ16U / TM3DQ16UG expansion module, its characteristics, and its connection to the different actuators.

### What Is in This Chapter?

This chapter contains the following topics:

Topic	Page
TM3DQ16U / TM3DQ16UG Presentation	140
TM3DQ16U / TM3DQ16UG Characteristics	142
TM3DQ16U / TM3DQ16UG Wiring Diagram	144

## TM3DQ16U / TM3DQ16UG Presentation

### Overview

TM3DQ16U (screw) and TM3DQ16UG (spring) digital expansion module:

- 16 channels
- 0.3 A sink outputs
- 1 common line
- Removable screw or spring terminal block

### Main Characteristics

Characteristic		Value
Number of output channels		16
Logic type		Sink
Rated output voltage		24 Vdc
Rated output current		0.3 A
Connection type	TM3DQ16U	Removable screw terminal blocks
	TM3DQ16UG	Removable spring terminal blocks
Cable type and length	Type	Unshielded
	length	Max. 30 m (98 ft)
Weight		76 g (2.70 oz)

### Status LEDs

The following figures show the status LEDs:

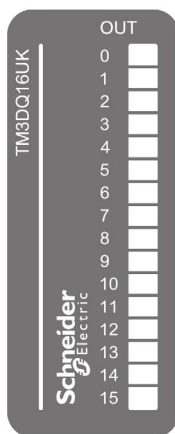

This table describes the status LEDs:

LED	Color	Status	Description
0...15	Green	On	The output channel is activated
		Off	The output channel is deactivated

## TM3DQ16U / TM3DQ16UG Characteristics

### Introduction

This section provides a description of the electrical and the output characteristics of the TM3DQ16U / TM3DQ16UG expansion modules.

See also Environmental Characteristics ([see page 29](#)).

## ⚠ WARNING

### UNINTENDED EQUIPMENT OPERATION

Do not exceed any of the rated values specified in the environmental and electrical characteristics tables.

**Failure to follow these instructions can result in death, serious injury, or equipment damage.**

### Dimensions

The following diagrams show the external dimensions for the TM3DQ16U / TM3DQ16UG expansion modules:

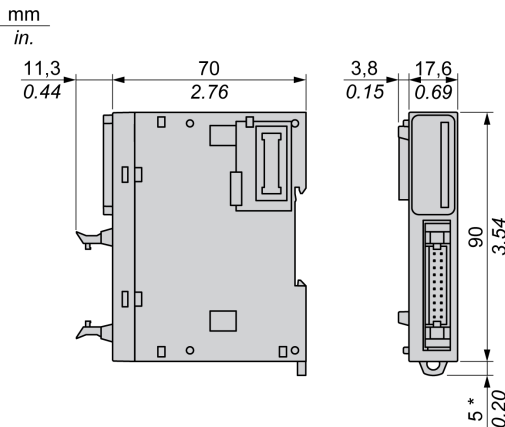

**NOTE:** \* 8.5 mm (0.33 in) when the clamp is pulled out.

## Output Characteristics

The table below describes the outputs characteristics of the TM3DQ16U and TM3DQ16UG:

Characteristic		Value
Number of output channels		16
Number of channel groups		1 common line on 2 pins for 16 channels
Output type		Transistor
Logic type		Sink
Rated output voltage		24 Vdc
Output voltage range		19.2...28.8 Vdc
Rated output current		0.3 A
Total output current		2 A
Voltage drop		0.4 Vdc max.
Leakage current when switched off		0.1 mA max.
Maximum power of filament lamp		12 W
Inductive load		L/R = 10 ms
De-rating	- 10...55 °C (14...131 °F)	No de-rating
Turn on time		450 µs
Turn off time		450 µs
Protection against short circuit		No fast external fuse required
Short circuit output peak current		N/A
Automatic rearming after short circuit or overload		N/A
Protection against reverse polarity		No
Clamping voltage		Typically 50 Vdc
Switching frequency	Under resistive load	100 Hz max.
Isolation	Between output and internal logic	500 Vac
	Between channel group	N/A
Connection type	TM3DQ16U	Removable screw terminal blocks
	TM3DQ16UG	Removable spring terminal blocks
Connector insertion/removal durability		Over 100 times
Current draw on 5 Vdc internal bus		15 mA (all outputs on) 5 mA (all outputs off)
Current draw on 24 Vdc internal bus		20 mA (all outputs on) 0 mA (all outputs off)
<b>NOTE:</b> Refer to Protecting Outputs from Inductive Load Damage ( <a href="#">see page 51</a> ) for additional information concerning output protection.		

## TM3DQ16U / TM3DQ16UG Wiring Diagram

### Introduction

These expansion modules have a built-in removable screw or spring terminal block connector for the connection of outputs and power supply.

### Wiring Rules

See Wiring Best Practices (*see page 47*).

### Wiring Diagram

The following figure illustrates the connections between the outputs, the actuators, and their commons:

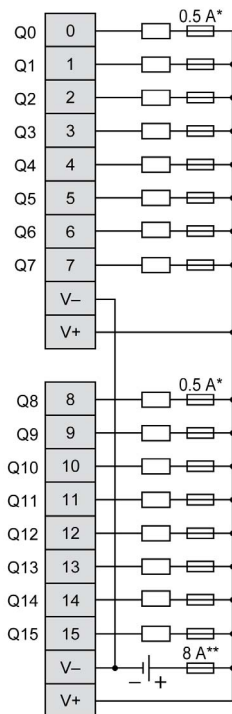

\* Type T fuse

\*\* Type F fuse

For information about 24 Vdc power supply, refer to DC Power Supply Characteristics (*see page 53*).



---

# Chapter 15

## TM3DQ16UK Module 16 Regular Transistor Sink Outputs 0.1A 24 Vdc

---

### Overview

This chapter describes the TM3DQ16UK expansion module, its characteristics, and its connection to the different actuators.

### What Is in This Chapter?

This chapter contains the following topics:

Topic	Page
TM3DQ16UK Presentation	146
TM3DQ16UK Characteristics	148
TM3DQ16UK Wiring Diagram	150

## TM3DQ16UK Presentation

### Overview

TM3DQ16UK (HE10) digital expansion module:

- 16 channels
- 0.1 A sink outputs
- 1 common line
- HE10 (MIL 20) connector

### Main Characteristics

Characteristic		Value
Number of output channels		16
Logic type		Sink
Rated output voltage		24 Vdc
Rated output current		0.1 A
Connection type		HE10 (MIL 20) connector
Cable type and length	Type	Unshielded
	length	Max. 5 m (16 ft)
Weight		111 g (3.90 oz)

### Status LEDs

The following figures show the status LEDs:

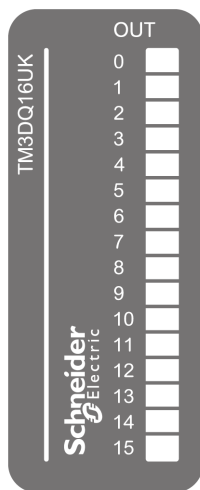

This table describes the status LEDs:

LED	Color	Status	Description
0...15	Green	On	The output channel is activated
		Off	The output channel is deactivated

## TM3DQ16UK Characteristics

### Introduction

This section provides a description of the electrical and the output characteristics of the TM3DQ16UK expansion module.

See also Environmental Characteristics ([see page 29](#)).

### **⚠ WARNING**

#### **UNINTENDED EQUIPMENT OPERATION**

Do not exceed any of the rated values specified in the environmental and electrical characteristics tables.

**Failure to follow these instructions can result in death, serious injury, or equipment damage.**

### Dimensions

The following diagrams show the external dimensions for the TM3DQ16UK expansion module:

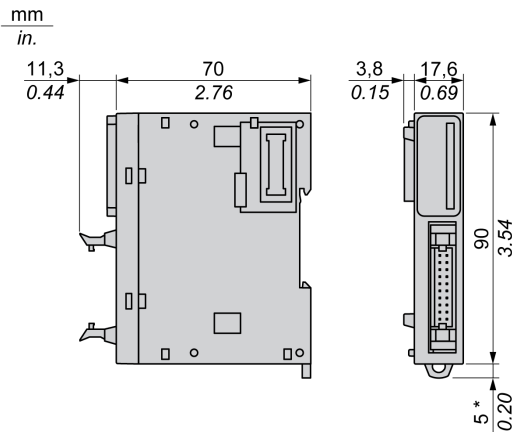

**NOTE:** \* 8.5 mm (0.33 in) when the clamp is pulled out.

## Output Characteristics

The table below describes the outputs characteristics of the TM3DQ16UK:

Characteristic		Value
Number of output channels		16
Number of channel groups		1 common line on 2 pins for 16 channels
Output type		Transistor
Logic type		Sink
Rated output voltage		24 Vdc
Output voltage range		19.2...28.8 Vdc
Rated output current		0.1 A
Total output current per group		2 A
Voltage drop		0.4 Vdc max.
Leakage current when switched off		0.1 mA max.
Maximum power of filament lamp		2.4 W
Inductive load		L/R = 10 ms
De-rating	- 10...55 °C (14...131 °F)	No de-rating
Turn on time		450 µs
Turn off time		450 µs
Protection against short circuit		No fast external fuse required
Short circuit output peak current		N/A
Automatic rearming after short circuit or overload		N/A
Protection against reverse polarity		No
Clamping voltage		Typically 50 Vdc
Switching frequency	Under resistive load	100 Hz max.
Isolation	Between output and internal logic	500 Vac
	Between channel group	N/A
Connection type		HE10 (MIL 20) connector
Connector insertion/removal durability		Over 100 times
Current draw on 5 Vdc internal bus		15 mA (all outputs on) 5 mA (all outputs off)
Current draw on 24 Vdc internal bus		20 mA (all outputs on) 0 mA (all outputs off)
<b>NOTE:</b> Refer to Protecting Outputs from Inductive Load Damage ( <a href="#">see page 51</a> ) for additional information concerning output protection.		

## TM3DQ16UK Wiring Diagram

### Introduction

These expansion modules have a built-in HE10 (MIL 20) connector for the connection of outputs and power supply.

Telefast sub-bases are not compatible with this module.

### Wiring Rules

See Wiring Best Practices (*see page 47*).

### Wiring Diagram

The following figure illustrates the connections between the outputs, the actuators, and their commons:

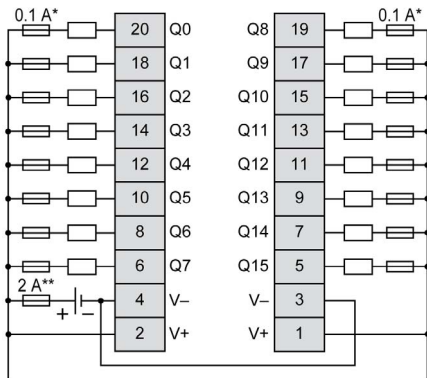

- \* Type T fuse
- \*\* Type F fuse

For information about 24 Vdc power supply, refer to DC Power Supply Characteristics (*see page 53*).

---

# Chapter 16

## TM3DQ32TK Module 32 Regular Transistor Outputs 0.1A 24 Vdc

---

### Overview

This chapter describes the TM3DQ32TK expansion module, its characteristics, and its connection to the different actuators.

### What Is in This Chapter?

This chapter contains the following topics:

Topic	Page
TM3DQ32TK Presentation	152
TM3DQ32TK Characteristics	154
TM3DQ32TK Wiring Diagram	156

## TM3DQ32TK Presentation

### Overview

TM3DQ32TK (HE10) digital expansion module:

- 32 channels
- 0.1 A source outputs
- 2 common lines
- HE10 (MIL 20) connector

### Main Characteristics

Characteristic		Value
Number of output channels		32
Logic type		Source
Rated output voltage		24 Vdc
Rated output current		0.1 A
Connection type		HE10 (MIL 20) connectors
Cable type and length	Type	Unshielded
	Length	Max. 5 m (16 ft)
Weight		112 g (3.90 oz)

### Status LEDs

The following figure shows the status LEDs:

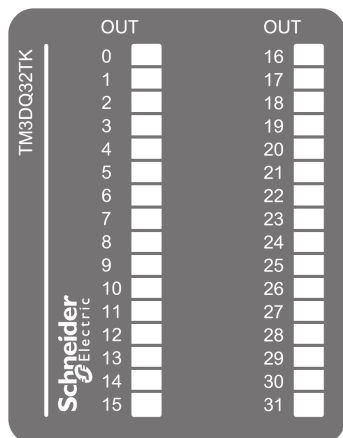



This table describes the status LEDs:

LED	Color	Status	Description
0...31	Green	On	The output channel is activated
		Off	The output channel is deactivated

## TM3DQ32TK Characteristics

### Introduction

This section provides a description of the electrical and output characteristics of the TM3DQ32TK expansion module.

See also Environmental Characteristics (*see page 29*).

## ⚠ WARNING

### UNINTENDED EQUIPMENT OPERATION

Do not exceed any of the rated values specified in the environmental and electrical characteristics tables.

**Failure to follow these instructions can result in death, serious injury, or equipment damage.**

### Dimensions

The following diagrams show the external dimensions for the TM3DQ32TK expansion modules:

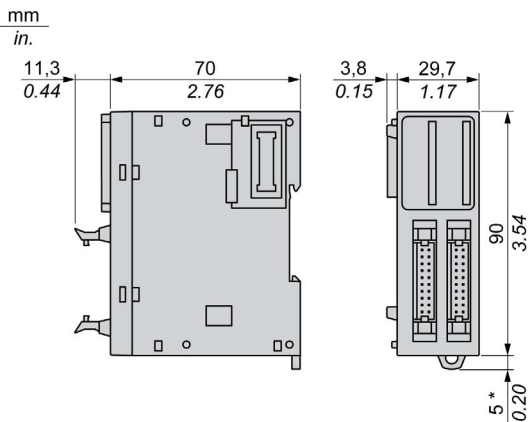

**NOTE:** \* 8.5 mm (0.33 in) when the clamp is pulled out.

## Output Characteristics

The table below describes the outputs characteristics of the TM3DQ32TK:

Characteristic		Value
Number of output channels		32
Number of channel groups		2 groups of 16 channels, 1 common line each on 2 pins
Output type		Transistor
Logic type		Source
Rated output voltage		24 Vdc
Output voltage range		19.2...28.8 Vdc
Rated output current		0.1 A
Total output current per group		2 A
Voltage drop		0.4 Vdc max.
Leakage current when switched off		0.1 mA max.
Maximum power of filament lamp		2.4 W
Inductive load		L/R = 10 ms
De-rating	- 10...55 °C (14...131 °F)	No de-rating
Turn on time		450 µs
Turn off time		450 µs
Protection against short circuit		yes
Short circuit output peak current		1 A typically
Automatic rearming after short circuit or overload		Yes, time depending on component temperature
Protection against reverse polarity		yes
Clamping voltage		Typically 50 Vdc
Switching frequency	Under resistive load	100 Hz max.
Isolation	Between output and internal logic	500 Vac
Connection type		HE10 (MIL 20) connectors
Connector insertion/removal durability		Over 100 times
Current draw on 5 Vdc internal bus		25 mA (all outputs on) 5 mA (all outputs off)
Current draw on 24 Vdc internal bus		40 mA (all outputs on) 0 mA (all outputs off)
<b>NOTE:</b> Refer to Protecting Outputs from Inductive Load Damage ( <i>see page 51</i> ) for additional information concerning output protection.		

## TM3DQ32TK Wiring Diagram

### Introduction

These expansion modules have two built-in HE10 (MIL 20) connectors for the connection of outputs and power supply.

### Wiring Rules

See Wiring Best Practices ([see page 47](#)).

### Wiring Diagram with Free-Wire Cables

The following figure illustrates the connections between the outputs, the actuators, and their commons:

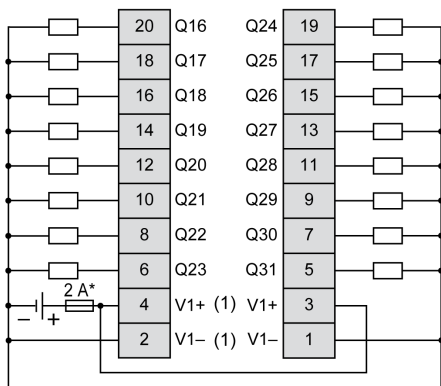
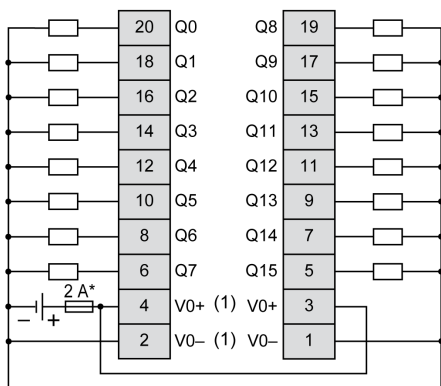

\* Type T fuse

- (1) The V0+ terminals are connected internally.
- The V0- terminals are connected internally.
- The V1+ terminals are connected internally.

The V1- terminals are connected internally.  
 The V0+ and V1+ terminals are not connected internally.  
 The V0- and V1- terminals are not connected internally.

For information about 24 Vdc power supply, refer to DC Power Supply Characteristics (see page 53).

For more information on the cable color for TWDFCW30K/TWDFCW50K, refer to TWDFCW••K Cable Description.

### Wiring Diagrams with Telefast ABE7E16SPN2•/ABE7E16SRM20 Pre-Wiring Sub-bases

The following figure shows the ABE7E16SPN20 sub-base:

TM221M32TK  
 TM221ME32TK

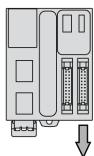

ABFT20E•••



ABE7E16SPN20

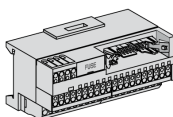

TM3DQ16TK  
 TM3DQ32TK

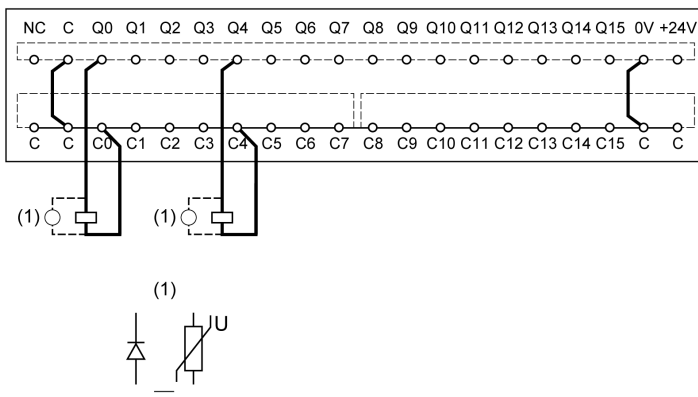
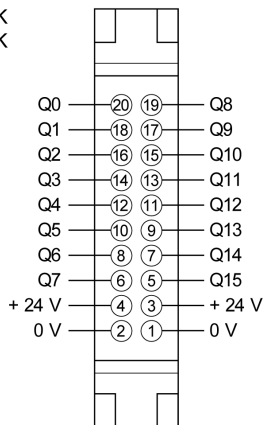
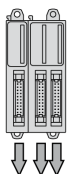

(1) To improve the life time of the contacts, and to protect from potential inductive load damage, it is recommended to connect a free wheeling diode in parallel to each inductive DC load or an RC snubber in parallel of each inductive AC load.

The following figure shows the ABE7E16SPN22 sub-base:

TM221M32TK  
TM221ME32TK

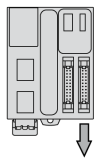

ABFT20E●●●



ABE7E16SPN22

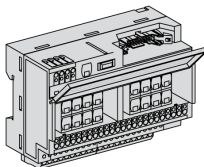

TM3DQ16TK  
TM3DQ32TK

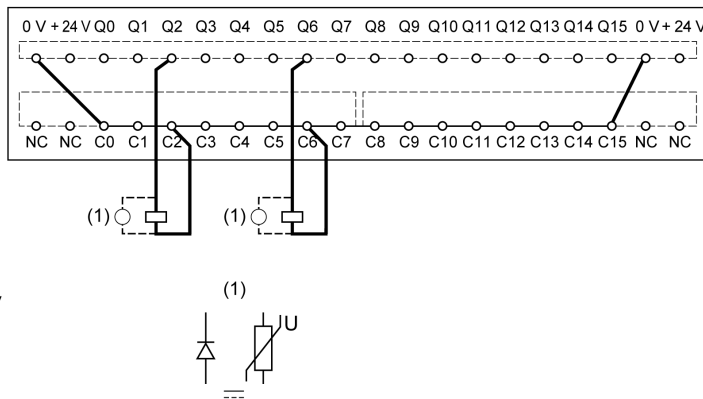
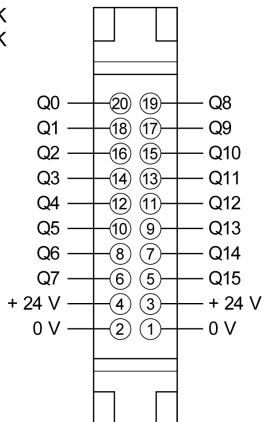
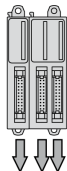

- (1) To improve the life time of the contacts, and to protect from potential inductive load damage, it is recommended to connect a free wheeling diode in parallel to each inductive DC load or an RC snubber in parallel of each inductive AC load.

The following figure shows the ABE7E16SRM20 sub-base:

TM221M32TK  
TM221ME32TK

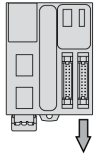

ABFT20E●●●



ABE7E16SRM20

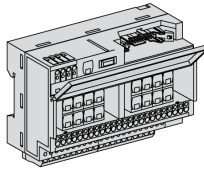

TM3DQ16TK  
TM3DQ32TK

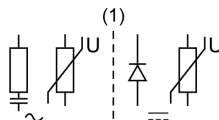
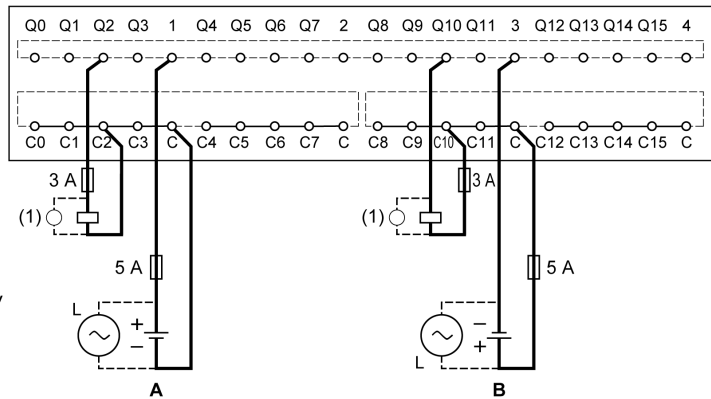
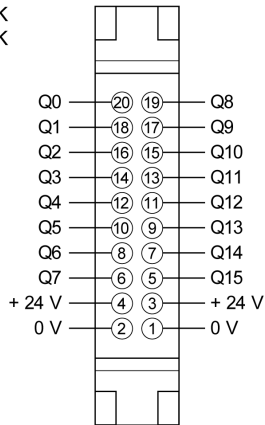
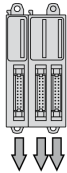

(1) To improve the life time of the contacts, and to protect from potential inductive load damage, it is recommended to connect a free wheeling diode in parallel to each inductive DC load or an RC snubber in parallel of each inductive AC load.

**A** Source wiring (positive logic)

**B** Sink wiring (negative logic)

For more information on the cable, refer to Telefast Pre-wiring Sub-bases ([see page 24](#)).





---

# Chapter 17

## TM3DQ32UK Module 32 Regular Transistor Outputs 0.1A 24 Vdc

---

### Overview

This chapter describes the TM3DQ32UK expansion module, its characteristics, and its connection to the different actuators.

### What Is in This Chapter?

This chapter contains the following topics:

Topic	Page
TM3DQ32UK Presentation	162
TM3DQ32UK Characteristics	164
TM3DQ32UK Wiring Diagram	166

## TM3DQ32UK Presentation

### Overview

TM3DQ32UK (HE10) digital expansion module:

- 32 channels
- 0.1 A sink outputs
- 2 common lines
- HE10 (MIL 20) connector

### Main Characteristics

Characteristic		Value
Number of output channels		32
Logic type		Sink
Rated output voltage		24 Vdc
Rated output current		0.1 A
Connection type		HE10 (MIL 20) connectors
Cable type and length	Type	Unshielded
	Length	Max. 5 m (16 ft)
Weight		112 g (3.90 oz)

### Status LEDs

The following figure shows the status LEDs:

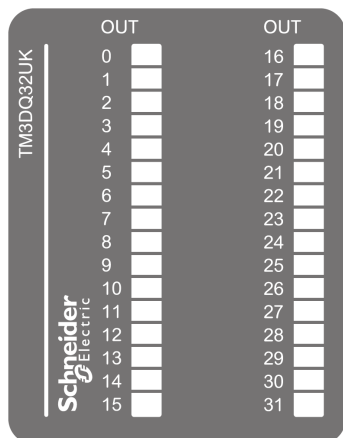

This table describes the status LEDs:

LED	Color	Status	Description
0...31	Green	On	The output channel is activated
		Off	The output channel is deactivated

## TM3DQ32UK Characteristics

### Introduction

This section provides a description of the electrical and output characteristics of the TM3DQ32UK expansion module.

See also Environmental Characteristics ([see page 29](#)).

## ⚠ WARNING

### UNINTENDED EQUIPMENT OPERATION

Do not exceed any of the rated values specified in the environmental and electrical characteristics tables.

**Failure to follow these instructions can result in death, serious injury, or equipment damage.**

### Dimensions

The following diagrams show the external dimensions for the TM3DQ32UK expansion module:

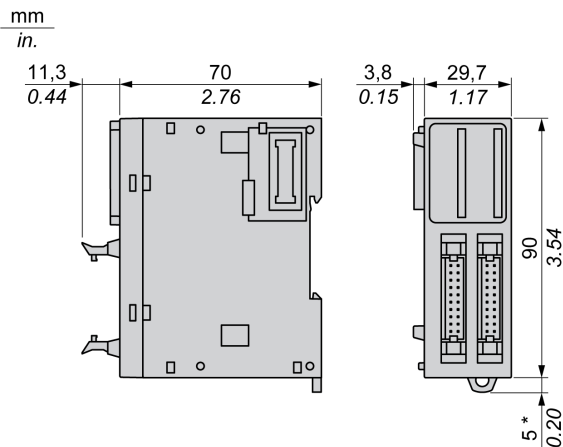

**NOTE:** \* 8.5 mm (0.33 in) when the clamp is pulled out.

## Output Characteristics

The table below describes the outputs characteristics of the TM3DQ32UK:

Characteristic		Value
Number of output channels		32
Number of channel groups		2 groups of 16 channels, 1 common line each on 2 pins
Output type		Transistor
Logic type		Sink
Rated output voltage		24 Vdc
Output voltage range		19.2...28.8 Vdc
Rated output current		0.1 A
Total output current per group		2 A
Voltage drop		0.4 Vdc max.
Leakage current when switched off		0.1 mA max.
Maximum power of filament lamp		2.4 W
Inductive load		L/R = 10 ms
De-rating	- 10...55 °C (14...131 °F)	No de-rating
Turn on time		450 µs
Turn off time		450 µs
Protection against short circuit		No fast external fuse required
Short circuit output peak current		N/A
Automatic rearming after short circuit or overload		N/A
Protection against reverse polarity		yes
Clamping voltage		Typically 50 Vdc
Switching frequency	Under resistive load	100 Hz max.
Isolation	Between output and internal logic	500 Vac
Connection type		HE10 (MIL 20) connectors
Connector insertion/removal durability		Over 100 times
Current draw on 5 Vdc internal bus		25 mA (all outputs on) 5 mA (all outputs off)
Current draw on 24 Vdc internal bus		40 mA (all outputs on) 0 mA (all outputs off)
<b>NOTE:</b> Refer to Protecting Outputs from Inductive Load Damage ( <a href="#">see page 51</a> ) for additional information concerning output protection.		

## TM3DQ32UK Wiring Diagram

### Introduction

These expansion modules have two built-in HE10 (MIL 20) connectors for the connection of outputs and power supply.

Telefast sub-bases are not compatible with this module.

### Wiring Rules

See Wiring Best Practices ([see page 47](#)).

### Wiring Diagram

The following figure illustrates the connections between the outputs, the actuators, and their commons:

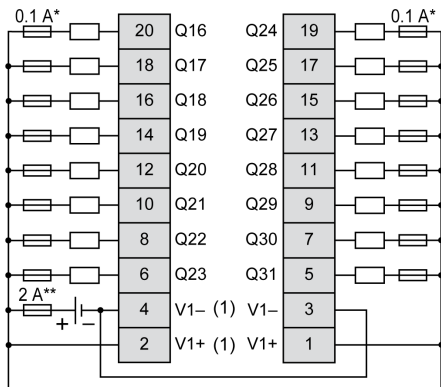
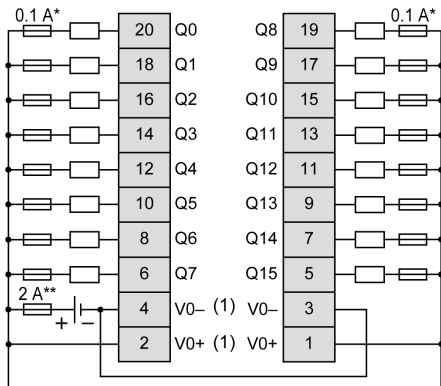

\* Type T fuse

\*\* Type F fuse

- (1) The V0+ terminals are connected internally.  
The V0- terminals are connected internally.  
The V1+ terminals are connected internally.  
The V1- terminals are connected internally.  
The V0+ and V1+ terminals are not connected internally.  
The V0- and V1- terminals are not connected internally.

For information about 24 Vdc power supply, refer to DC Power Supply Characteristics  
([see page 53](#)).





---

# Part IV

## TM3 Digital Mixed Input/Output Modules

---

### What Is in This Part?

This part contains the following chapters:

Chapter	Chapter Name	Page
18	TM3DM8R / TM3DM8RG Mixed I/O Module 4 Inputs/4 Outputs	171
19	TM3DM24R / TM3DM24RG Mixed I/O Module 16 Inputs/8 Outputs	181



---

# Chapter 18

## TM3DM8R / TM3DM8RG Mixed I/O Module 4 Inputs/4 Outputs

---

### Overview

This chapter describes the TM3DM8R / TM3DM8RG expansion module, its characteristics, and its connection to the different sensors and actuators.

### What Is in This Chapter?

This chapter contains the following topics:

Topic	Page
TM3DM8R / TM3DM8RG Presentation	172
TM3DM8R / TM3DM8RG Characteristics	174
TM3DM8R / TM3DM8RG Wiring Diagram	180

## TM3DM8R / TM3DM8RG Presentation

### Overview

TM3DM8R (screw) and TM3DM8RG (spring) digital expansion module:

- 4 channel 24 Vdc sink/source inputs
- 1 common line for inputs
- 4 channel 2 A relay outputs
- 1 common line for outputs
- Removable screw or spring terminal block

### Main Characteristics

Characteristic		Value
<b>Input</b>		
Number of input channels		4 inputs
Input type		Type 1 (IEC/EN 61131-2)
Input Logic type		Sink/source
Rated input voltage		24 Vdc
<b>Output</b>		
Number of output channels		4 outputs
Output type		Relay
Contact type		NO (Normally Open)
Rated output voltage		24 Vdc / 240 Vac
Rated output current		2 A
<b>Connection and cable types</b>		
Connection type	TM3DM8R	Removable screw terminal block
	TM3DM8RG	Removable spring terminal block
Cable type and length	Type	Unshielded
	Length	Max. 30 m (98 ft)
Weight		95 g (3.35 oz)

### Status LEDs

The following figure shows the status LEDs:



This table describes the status LEDs:

LED	Color	Status	Type	Description
0...3	Green	On	Input	The channel is activated
		Off		The channel is deactivated
0...3	Green	On	Output	The channel is activated
		Off		The channel is deactivated

## TM3DM8R / TM3DM8RG Characteristics

### Introduction

This section describes the general characteristics of the TM3DM8R / TM3DM8RG expansion module.

See also Environmental Characteristics ([see page 29](#)).

### DANGER

#### FIRE HAZARD

- Use only the recommended wire sizes for the current capacity of the I/O channels and power supplies.
- For relay output (2 A) wiring, use conductors of at least 0.5 mm<sup>2</sup> (AWG 20) with a temperature rating of at least 80 °C (176 °F).
- For common conductors of relay output wiring (7 A), or relay output wiring greater than 2 A, use conductors of at least 1.0 mm<sup>2</sup> (AWG 16) with a temperature rating of at least 80 °C (176 °F).

**Failure to follow these instructions will result in death or serious injury.**

### WARNING

#### UNINTENDED EQUIPMENT OPERATION

Do not exceed any of the rated values specified in the environmental and electrical characteristics tables.

**Failure to follow these instructions can result in death, serious injury, or equipment damage.**

## Dimensions

The following diagrams show the external dimensions for the TM3DM8R / TM3DM8RG expansion modules:

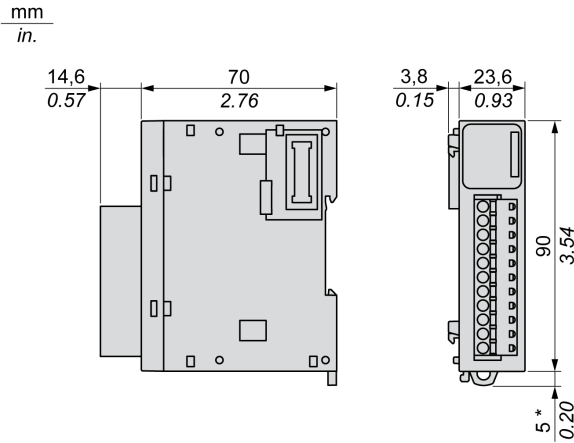

**NOTE:** \* 8.5 mm (0.33 in.) when the clamp is pulled out.

## Input Characteristics

The table below describes the inputs characteristics of the TM3DM8R / TM3DM8RG:

Characteristic		Value
Number of input channels		4 inputs
Number of channels groups		1 common line for 4 channels
Input type		Type 1 (IEC/EN 61131-2)
Logic type		Sink/source
Rated input voltage		24 Vdc
Input voltage range		19.2...28.8 Vdc
Rated input current		7 mA
Input impedance		3.4 kΩ
Input limit values	Voltage at state 1	> 15 Vdc (15..28.8Vdc)
	Voltage at state 0	< 5 Vdc (0..5 Vdc)
	Current at state 1	> 2.5 mA
	Current at state 0	< 1.0 mA
Turn on time		4 ms
Turn off time		4 ms

Characteristic		Value
De-rating	-10...55 °C (14...131 °F)	No de-rating
Isolation	Between input and internal logic	500 Vac
	Between input group and output group	1500 Vac
	Between input groups	N/A
Connection type	TM3DM8R	Removable screw terminal block
	TM3DM8RG	Removable spring terminal block
Connector insertion/removal durability		Over 100 times
Current draw on 5 Vdc internal bus		25 mA (all inputs and outputs on)
		5 mA (all inputs and outputs off)
Current draw on 24 Vdc internal bus		0 mA (all inputs and outputs on)
		0 mA (all inputs and outputs off)

### Output Characteristics

The table below describes the outputs characteristics of the TM3DM8R / TM3DM8RG:

Characteristic	Value
Number of output channels	4 outputs
Number of channel groups	1 common line for 4 channels
Output type	Relay
Contact type	NO (Normally Open)
Rated output voltage	24 Vdc, 240 Vac
Maximum voltage	30 Vdc, 264 Vac
Minimum switching load	5 Vdc at 10 mA
Rated output current	2 A
Maximum output current	2 A per output
	7 A per common
Maximum output frequency	20 operations per minute
Turn on time	Max. 10 ms
Turn off time	Max. 10 ms
Contact resistance	30 mΩ max
Mechanical life	20 million operations



Characteristic		Value
Electrical life	Under resistive load	See Power Limitation ( <i>see page 179</i> )
	Under inductive load	
Protection against short circuit		No
Isolation	Between input and internal logic	500 Vac
	Between input group and output group	1500 Vac
	Between input groups	N/A
Connection type	TM3DM8R	Removable screw terminal block
	TM3DM8RG	Removable spring terminal block
Connector insertion/removal durability		Over 100 times
Current draw on 5 Vdc internal bus		25 mA (all inputs and outputs on)
		5 mA (all inputs and outputs off)
Current draw on 24 Vdc internal bus		0 mA (all inputs and outputs on)
		0 mA (all inputs and outputs off)
<b>NOTE:</b> Refer to Protecting Outputs from Inductive Load Damage ( <i>see page 47</i> ) for additional information on this topic.		

**I/O De-rating**

When using TM3DM8R / TM3DM8RG:

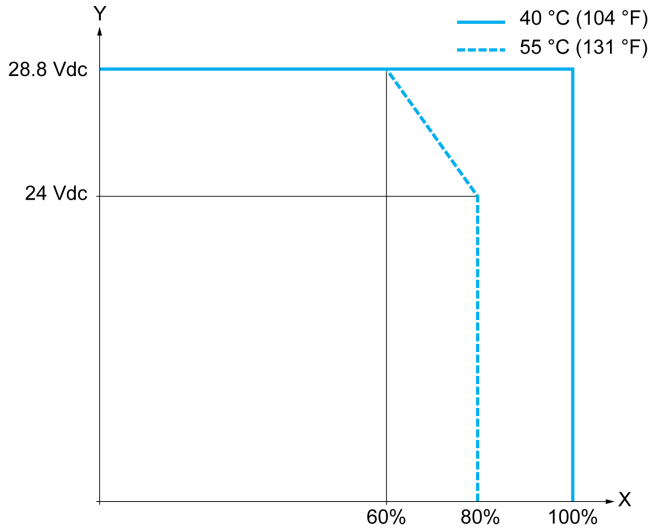

At an ambient temperature of 55 °C (131 °F) in the horizontal mounting direction, limit the inputs and outputs, respectively, which turn on simultaneously as indicated by the X axis.

At 40 °C (104 °F), all inputs and outputs can be turned on simultaneously at 28.8 Vdc.

**Power Limitation**

This table describes the power limitation of the TM3DM8R / TM3DM8RG expansion module depending on the voltage, the type of load, and the number of operations required.

These expansion modules do not support capacitive loads.

<b> WARNING</b>
<b>RELAY OUTPUTS WELDED CLOSED</b>
<ul style="list-style-type: none"> <li>● Always protect relay outputs from inductive alternating current load damage using an appropriate external protective circuit or device.</li> <li>● Do not connect relay outputs to capacitive loads.</li> </ul> <p><b>Failure to follow these instructions can result in death, serious injury, or equipment damage.</b></p>

Power Limitations				
Voltage	24 Vdc	120 Vac	240 Vac	Number of operations
Power of resistive loads AC-12	–	240 VA 80 VA	480 VA 160 VA	100,000 300,000
Power of inductive loads AC-15 (cos φ = 0.35)	–	60 VA 18 VA	120 VA 36 VA	100,000 300,000
Power of inductive loads AC-14 (cos φ = 0.7)	–	120 VA 36 VA	240 VA 72 VA	100,000 300,000
Power of resistive loads DC-12	48 W 16 W	–	–	100,000 300,000
Power of inductive loads DC-13 L/R = 7 ms	24 W 7.2 W	–	–	100,000 300,000

## TM3DM8R / TM3DM8RG Wiring Diagram

### Introduction

These expansion modules have a built-in removable screw or spring terminal block for the connection of inputs, outputs, and power supply.

### Wiring Rules

See Wiring Best Practices ([see page 47](#)).

### Wiring Diagram

The following figure illustrates the connections between the inputs and outputs, the sensors and actuators, and their commons:

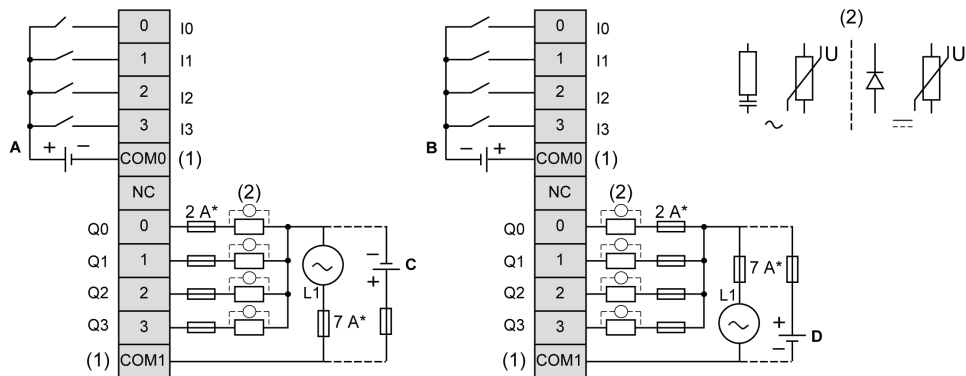

\* Type T Fuse

- (1) The COM0 and COM1 terminals are **not** connected internally.
- (2) To improve the life time of the contacts, and to protect from potential inductive load damage, connect a free wheeling diode in parallel to each inductive DC load or an RC snubber in parallel of each inductive AC load.
- C Source wiring (positive logic)
- D Sink wiring (negative logic)

For information about 24 Vdc power supply, refer to DC Power Supply Characteristics ([see page 53](#)).

## ⚠ WARNING

### UNINTENDED EQUIPMENT OPERATION

Do not connect wires to unused terminals and/or terminals indicated as “No Connection (N.C.)”.

**Failure to follow these instructions can result in death, serious injury, or equipment damage.**

---

# Chapter 19

## TM3DM24R / TM3DM24RG Mixed I/O Module 16 Inputs/8 Outputs

---

### Overview

This chapter describes the TM3DM24R / TM3DM24RG expansion modules, its characteristics, and its connection to the different sensors and actuators.

### What Is in This Chapter?

This chapter contains the following topics:

Topic	Page
TM3DM24R / TM3DM24RG Presentation	182
TM3DM24R / TM3DM24RG Characteristics	184
TM3DM24R / TM3DM24RG Wiring Diagram	189

## TM3DM24R / TM3DM24RG Presentation

### Overview

TM3DM24R (screw) and TM3DM24RG (spring) digital expansion module:

- 16 channel 24 Vdc sink/source inputs
- 1 common line for inputs
- 8 channel 2 A relay outputs
- 2 common line for outputs
- Removable screw or spring terminal block

### Main Characteristics

Characteristic		Value
<b>Input</b>		
Number of input channels		16 inputs
Input type		Type 1 (IEC/EN 61131-2)
Input Logic type		Sink/Source
Rated input voltage		24 Vdc
<b>Output</b>		
Number of output channels		8 outputs
Contact type		NO (Normally Open)
Rated output voltage		24 Vdc / 240 Vdc
Rated output current		2 A
<b>Connection and cable types</b>		
Connection type	TM3DM24R	Removable screw terminal blocks
	TM3DM24RG	Removable spring terminal blocks
Cable type and length	Type	Unshielded
	Length	Max. 30 m (98 ft)
Weight		140 g (4.94 oz)

### Status LEDs

The following figure shows the status LEDs:

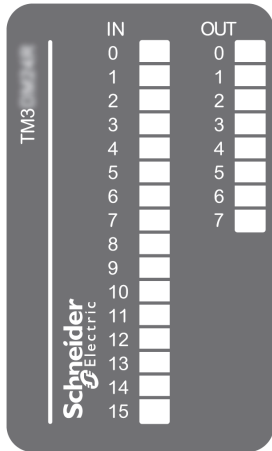

This table describes the status LEDs:

LED	Color	Status	Type	Description
0...15	Green	On	Input	The channel is activated
		Off		The channel is deactivated
0...7	Green	On	Output	The channel is activated
		Off		The channel is deactivated

## TM3DM24R / TM3DM24RG Characteristics

### Introduction

This section provides a description of the electrical and input/output characteristics of the TM3DM24R / TM3DM24RG expansion modules.

See also Environmental Characteristics ([see page 29](#)).

### DANGER

#### **FIRE HAZARD**

- Use only the recommended wire sizes for the current capacity of the I/O channels and power supplies.
- For relay output (2 A) wiring, use conductors of at least 0.5 mm<sup>2</sup> (AWG 20) with a temperature rating of at least 80 °C (176 °F).
- For common conductors of relay output wiring (7 A), or relay output wiring greater than 2 A, use conductors of at least 1.0 mm<sup>2</sup> (AWG 16) with a temperature rating of at least 80 °C (176 °F).

**Failure to follow these instructions will result in death or serious injury.**

### WARNING

#### **UNINTENDED EQUIPMENT OPERATION**

Do not exceed any of the rated values specified in the environmental and electrical characteristics tables.

**Failure to follow these instructions can result in death, serious injury, or equipment damage.**



## Dimensions

The following diagrams show the external dimensions for the TM3DM24R / TM3DM24RG expansion modules:

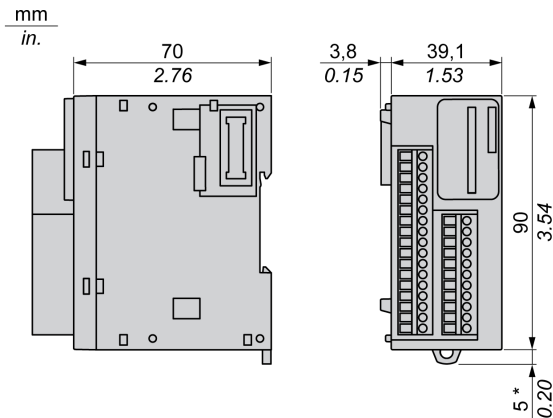

**NOTE:** \* 8.5 mm (0.33 in) when the clamp is pulled out.

## Input Characteristics

The table below describes the inputs characteristics of the TM3DM24R / TM3DM24RG:

Characteristic		Value
Number of input channels		16 inputs
Number of channels groups		1 common line for 16 channels
Input type		Type 1 (IEC/EN 61131-2)
Logic type		Sink/source
Rated input voltage		24 Vdc
Input voltage range		19.2...28.8 Vdc
Rated input current		7 mA
Input impedance		3.4 kΩ
Input limit values	Voltage at state 1	> 15 Vdc (15...28.8 Vdc)
	Voltage at state 0	< 5 Vdc (0...5 Vdc)
	Current at state 1	> 2.5 mA
	Current at state 0	< 1.0 mA
Turn on time		4 ms
Turn off time		4 ms

Characteristic		Value
Isolation	Between input and internal logic	500 Vac
	Between input group and output group	1500 Vac
	Between input groups	N/A
Connection type	TM3DM24R	Removable screw terminal block
	TM3DM24RG	Removable spring terminal block
Connector insertion/removal durability		Over 100 times
Current draw on 5 Vdc internal bus		65 mA (all inputs and outputs on)
		5 mA (all inputs and outputs off)
Current draw on 24 Vdc internal bus		0 mA (all inputs and outputs on)
		0 mA (all inputs and outputs off)

## Output Characteristics

The table below describes the outputs characteristics of the TM3DM24R / TM3DM24RG

Characteristic		Value
Number of output channels		8
Number of channel groups		2 common line for 8 channels
Output type		Relay
Contact type		NO (Normally Open)
Rated output voltage		24 Vdc, 240 Vac
Maximum voltage		30 Vdc, 264 Vac
Minimum switching load		5 Vdc at 10 mA
Rated output current		2 A
Maximum output current		2 A per channels
		7 A per commons
Maximum output frequency	with maximum load	20 operations per minute
Turn on time		Max. 10 ms
Turn off time		Max. 10 ms
Contact resistance		30 mW
Mechanical life		20 million operations
Electrical life	Under resistive load	See Power limitation ( <a href="#">see page 101</a> )
	Under inductive load	
Protection against short circuit		No

Characteristic		Value
Isolation	Between input and internal logic	500 Vac
	Between input group and output group	1500 Vac
	Between input groups	N/A
Connection type	TM3DM24R	Removable screw terminal block
	TM3DM24RG	Removable spring terminal block
Connector insertion/removal durability		Over 100 times
Current draw on 5 Vdc internal bus		65 mA (all inputs and outputs on) 5 mA (all inputs and outputs off)
Current draw on 24 Vdc internal bus		0 mA (all inputs and outputs on) 0 mA (all inputs and outputs off)
<b>NOTE:</b> Refer to Protecting Outputs from Inductive Load Damage ( <a href="#">see page 47</a> ) for additional information on this topic.		

### I/O De-rating

When using TM3DM24R / TM3DM24RG

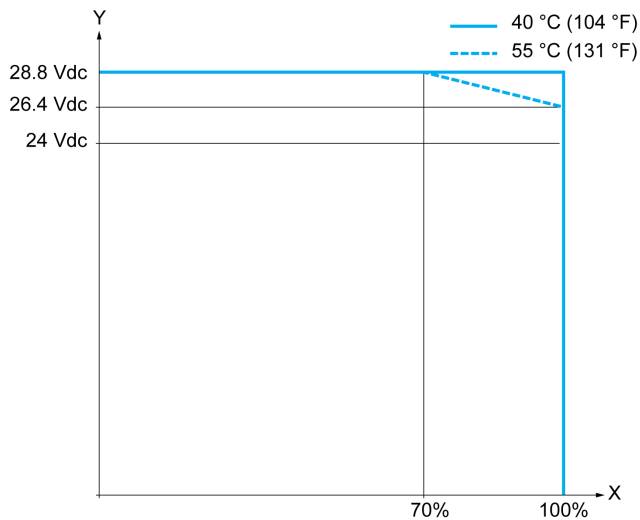

- X Input simultaneous ON ratio
- Y Input voltage

### Power Limitation

This table describes the power limitation of the TM3DM24R / TM3DM24RG expansion modules depending on the voltage, the type of load, and the number of operations required.

These expansion modules do not support capacitive loads.

## WARNING

### RELAY OUTPUTS WELDED CLOSED

- Always protect relay outputs from inductive alternating current load damage using an appropriate external protective circuit or device.
- Do not connect relay outputs to capacitive loads.

**Failure to follow these instructions can result in death, serious injury, or equipment damage.**

Power Limitations				
Voltage	24 Vdc	120 Vac	240 Vac	Number of operations
Power of resistive loads AC-12	–	240 VA 80 VA	480 VA 160 VA	100,000 300,000
Power of inductive loads AC-15 (cos φ = 0.35)	–	60 VA 18 VA	120 VA 36 VA	100,000 300,000
Power of inductive loads AC-14 (cos φ = 0.7)	–	120 VA 36 VA	240 VA 72 VA	100,000 300,000
Power of resistive loads DC-12	48 W 16 W	–	–	100,000 300,000
Power of inductive loads DC-13 L/R = 7 ms	24 W 7.2 W	–	–	100,000 300,000

## TM3DM24R / TM3DM24RG Wiring Diagram

### Introduction

These expansion modules have a built-in removable screw or spring terminal block for the connection of inputs, outputs, and power supply.

### Wiring Rules

See Wiring Best Practices ([see page 47](#)).

### Wiring Diagram

The following figure illustrates the connections between the inputs and outputs, the sensors and actuators, and their commons for a positive logic:

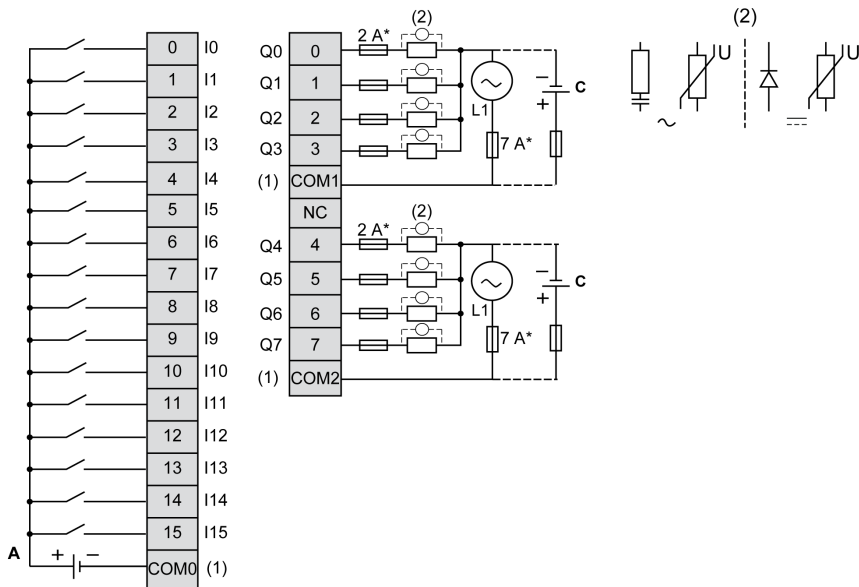

\* Type T Fuse

(1) The COM0, COM1 and COM2 terminals are **not** connected internally.

(2) To improve the life time of the contacts, and to protect from potential inductive load damage, connect a free wheeling diode in parallel to each inductive DC load or an RC snubber in parallel of each inductive AC load.

C Source wiring (positive logic)

The following figure illustrates the connections between the inputs and outputs, the sensors and actuators, and their commons for a negative logic:

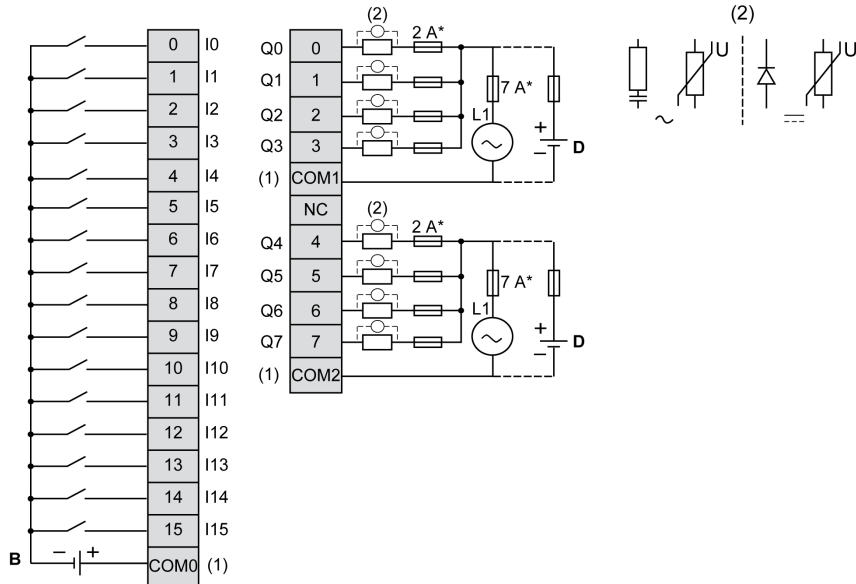

\* Type T Fuse

(1) The COM0, COM1 and COM2 terminals are **not** connected internally.

(2) To improve the life time of the contacts, and to protect from potential inductive load damage, connect a free wheeling diode in parallel to each inductive DC load or an RC snubber in parallel of each inductive AC load.

D Sink wiring (negative logic)

For information about 24 Vdc power supply, refer to DC Power Supply Characteristics (see page 53).

## ⚠ WARNING

### UNINTENDED EQUIPMENT OPERATION

Do not connect wires to unused terminals and/or terminals indicated as "No Connection (N.C.)".

**Failure to follow these instructions can result in death, serious injury, or equipment damage.**



## E

### **EIA rack**

(*electronic industries alliance rack*) A standardized (EIA 310-D, IEC 60297, and DIN 41494 SC48D) system for mounting various electronic modules in a stack or rack that is 19 inches (482.6 mm) wide.

### **EN**

EN identifies 1 of many European standards maintained by CEN (*European Committee for Standardization*), CENELEC (*European Committee for Electrotechnical Standardization*), or ETSI (*European Telecommunications Standards Institute*).

### **expansion connector**

A connector to attach expansion I/O modules.

## H

### **HE10**

Rectangular connector for electrical signals with frequencies below 3 MHz, complying with IEC 60807-2.

## I

### **IEC**

(*international electrotechnical commission*) A non-profit and non-governmental international standards organization that prepares and publishes international standards for electrical, electronic, and related technologies.

### **IP 20**

(*ingress protection*) The protection classification according to IEC 60529 offered by an enclosure, shown by the letter IP and 2 digits. The first digit indicates 2 factors: helping protect persons and for equipment. The second digit indicates helping protect against water. IP 20 devices help protect against electric contact of objects larger than 12.5 mm, but not against water.

## N

### **N/O**

(*normally open*) A contact pair that opens when the actuator is de-energized (no power is applied) and closes when the actuator is energized (power is applied).

### **NEMA**

(*national electrical manufacturers association*) The standard for the performance of various classes of electrical enclosures. The NEMA standards cover corrosion resistance, ability to help protect from rain, submersion, and so on. For IEC member countries, the IEC 60529 standard classifies the ingress protection rating for enclosures.

## R

### **RJ-45**

A standard type of 8-pin connector for network cables defined for Ethernet.

## T

### **terminal block**

(*terminal block*) The component that mounts in an electronic module and provides electrical connections between the controller and the field devices.





## A

accessories, 22  
assembling to a controller, 41

## C

certifications and standards, 32  
characteristics  
    TM3DI16/TM3DI16G, 72  
    TM3DI16K, 80  
    TM3DI32K, 88  
    TM3DI8/TM3DI8G, 66  
    TM3DI8A, 59  
    TM3DM24R/TM3DM24RG, 184  
    TM3DM8R/TM3DM8RG, 174  
    TM3DQ16R/TM3DQ16RG, 118  
    TM3DQ16T/TM3DQ16TG, 126  
    TM3DQ16TK, 132  
    TM3DQ16U/TM3DQ16UG, 142  
    TM3DQ16UK, 148  
    TM3DQ32TK, 154  
    TM3DQ32UK, 164  
    TM3DQ8R/TM3DQ8RG, 98  
    TM3DQ8T/TM3DQ8TG, 105  
    TM3DQ8U/TM3DQ8UG, 111  
controllers  
    disassembling a module, 43

## D

Digital I/O modules, 16  
digital I/O modules  
    specifications, 16, 17, 19

## E

Electromagnetic Susceptibility, 31  
environmental characteristics, 29

## I

Inductive Load, Output Protection  
    Output Protection, Inductive Load, 51

## M

minimum clearances, 37  
mounting position, 37

## P

physical description  
    TM3 I/O expansion modules, 20  
Power Supply, 53  
presentation  
    TM3DI16/TM3DI16G, 70  
    TM3DI16K, 78  
    TM3DI32K, 86  
    TM3DI8/TM3DI8G, 64  
    TM3DI8A, 58  
    TM3DM24R/TM3DM24RG, 182  
    TM3DM8R/TM3DM8RG, 172  
    TM3DQ16R/TM3DQ16RG, 116  
    TM3DQ16T/TM3DQ16TG, 124  
    TM3DQ16TK, 130  
    TM3DQ16U/TM3DQ16UG, 140  
    TM3DQ16UK, 146  
    TM3DQ32TK, 152  
    TM3DQ32UK, 162  
    TM3DQ8R/TM3DQ8RG, 96  
Presentation  
    TM3DQ8U/TM3DQ8UG, 110

## R

regular inputs, 16, 17, 19  
regular transistor outputs, 16, 17, 19  
relay outputs, 16, 17, 19

**S**

## specifications

- digital I/O modules, *16, 17, 19*

**T**

## TM3 digital I/O expansion modules

- TM3DM24R/TM3DM24RG, *181*
- TM3DM8R/TM3DM8RG, *171*
- TM3DQ16R/TM3DQ16RG, *115*
- TM3DQ16T/TM3DQ16TG, *123*
- TM3DQ16TK, *129*
- TM3DQ16U/TM3DQ16UG, *139*
- TM3DQ16UK, *145*
- TM3DQ32TK, *151*
- TM3DQ32UK, *161*
- TM3DQ8R/TM3DQ8RG, *95*
- TM3DQ8T/TM3DQ8TG, *103*
- TM3DQ8U/TM3DQ8UG, *109*

## TM3 digital I/O expansion modules inputs

- TM3DI16/TM3DI16G, *69*
- TM3DI16K, *77*
- TM3DI32K, *85*
- TM3DI8/TM3DI8G, *63*
- TM3DI8A, *57*

## TM3 I/O expansion modules

- physical description, *20*

## TM3 presentation

- TM3DQ8T/TM3DQ8TG, *104*

## TM3DI16/TM3DI16G

- characteristics, *72*
- presentation, *70*
- TM3 digital I/O expansion modules inputs, *69*
- wiring diagram, *75*

## TM3DI16K

- characteristics, *80*
- presentation, *78*
- TM3 digital I/O expansion modules inputs, *77*
- wiring diagram, *83*

## TM3DI32K

- characteristics, *88*
- presentation, *86*
- TM3 digital I/O expansion modules inputs,

- 85*

- wiring diagram, *91*

## TM3DI8/TM3DI8G

- characteristics, *66*
- presentation, *64*
- TM3 digital I/O expansion modules inputs, *63*
- wiring diagram, *68*

## TM3DI8A

- characteristics, *59*
- presentation, *58*
- TM3 digital I/O expansion modules inputs, *57*
- wiring diagram, *61*

## TM3DM24R/TM3DM24RG

- characteristics, *184*
- presentation, *182*
- TM3 digital I/O expansion modules, *181*
- wiring diagram, *189*

## TM3DM8R/TM3DM8RG

- characteristics, *174*
- presentation, *172*
- TM3 digital I/O expansion modules, *171*
- wiring diagram, *180*

## TM3DQ16R/TM3DQ16RG

- characteristics, *118*
- presentation, *116*
- TM3 digital I/O expansion modules, *115*
- wiring diagram, *121*

## TM3DQ16T/TM3DQ16TG

- characteristics, *126*
- presentation, *124*
- TM3 digital I/O expansion modules, *123*
- wiring diagram, *128*

## TM3DQ16TK

- characteristics, *132*
- presentation, *130*
- TM3 digital I/O expansion modules, *129*
- wiring diagram, *134*

## TM3DQ16U/TM3DQ16UG

- TM3 digital I/O expansion modules, *139*

## TM3DQ16U/TM3DQ16UG

- characteristics, *142*
- presentation, *140*
- wiring diagram, *144*

TM3DQ16UK  
characteristics, 148  
presentation, 146  
TM3 digital I/O expansion modules, 145  
wiring diagram, 150

TM3DQ32K  
TM3 digital I/O expansion modules, 161

TM3DQ32TK  
characteristics, 154  
presentation, 152  
TM3 digital I/O expansion modules, 151  
wiring diagram, 156

TM3DQ32UK  
characteristics, 164  
presentation, 162  
wiring diagram, 166

TM3DQ8R/TM3DQ8RG  
characteristics, 98  
presentation, 96  
TM3 digital I/O expansion modules, 95

TM3DQ8T/TM3DQ8TG  
characteristics, 105  
TM3 digital I/O expansion modules, 103  
TM3 presentation, 104  
wiring diagram, 107

TM3DQ8U/TM3DQ8UG  
characteristics, 111  
Presentation, 110  
TM3 digital I/O expansion modules, 109  
wiring diagram, 113

## W

wiring diagram  
TM3DI16/TM3DI16G, 75  
TM3DI16K, 83  
TM3DI32K, 91  
TM3DI8/TM3DI8G, 68  
TM3DI8A, 61  
TM3DM24R/TM3DM24RG, 189  
TM3DM8R/TM3DM8RG, 180  
TM3DQ16R/TM3DQ16RG, 121  
TM3DQ16T/TM3DQ16TG, 128  
TM3DQ16TK, 134  
TM3DQ16U/TM3DQ16UG, 144  
TM3DQ16UK, 150  
TM3DQ32TK, 156  
TM3DQ32UK, 166  
TM3DQ8T/TM3DQ8TG, 107  
TM3DQ8U/TM3DQ8UG, 113  
wiring rules, 47

